

INSTRUCTION BOOK

MODEL

2-B

COMMUNICATION RECEIVER

R. L. DRAKE COMPANY

MIAMISBURG, OHIO

I. GENERAL DESCRIPTION

The DRAKE 2-B is an extremely versatile communication receiver designed to bring you top performance in reception of all modes of amateur transmission in a compact package.

Basically, it is a triple conversion superheterodyne receiver employing crystal controlled high frequency oscillators, a highly stable variable oscillator tuning the same range on all bands, and for selectivity a steep-sided L-C filter at the 50 Kc I.F.

The receiver provides front panel control of a wide variety of functions such as band width, AVC time constants, type of detector used, and variable pass-band tuning for Single Sideband reception at its best. Switching is also available on the front panel for the 2-AC accessory crystal calibrator.

Separate tuning of the RF stage assists in peaking the receiver on the desired signal. Amplified, delayed action AVC with a selection of the proper time constants for your individual application add further to the set's versatility.

A direct reading 7 inch slide rule dial together with adjustable subdividing scale on the main tuning dial provide easy and accurate frequency readings on all ham bands. A logging scale is also provided for reading frequency of additional 600 Kc wide bands which may be added by purchase of accessory crystals. Five of these bands can be set-up at a time and selected by the band switch.

Separate detectors are provided for best performance whether listening to AM, CW, or SSB.

MODEL 2-B COMMUNICATIONS RECEIVER REFERENCE DATA

OPERATING RANGE: Twelve 600 kc segments may be selected between 3.5 and 30 mc. As originally supplied, crystals are provided for five ham band ranges:

80 meters (3.5 - 4.1 mc), 40 meters (6.9 - 7.5 mc),
20 meters (13.9 - 14.5 mc), 15 meters (20.9 - 21.5 mc),
10 meters (28.5 - 29.1 mc).

Band switch provides for addition of two ham ranges (28.0 - 28.6 mc) and (29.1 - 29.7 mc) and up to five universal ranges with accessory crystals to cover the frequencies desired. (WWV, MARS, Citizens band, etc.)

MODE: Selectable Single Sideband with product detector, Amplitude Modulation with diode or product detector, CW with either detector.

SELECTIVITY: .5 kc at 6 db down, 2.75 kc at 60 db down; 2.1 kc at 6 db down, 7.5 kc at 60 db down; 3.6 at 6 db down, 10.5 kc at 60 db down. Selectivity switching is independent of detector switching.

SPURIOUS RESPONSES: Image rejection more than 60 db; IF rejection more than 60 db on ham ranges; Internal spurious signals within ham bands less than that from a 1 microvolt antenna signal.

FREQUENCY STABILITY: Less than 400 cycles warm up; less than 100 cycles after warm up; less than 100 cycles for 10% line voltage change.

DIAL CALIBRATION: 10 kc main dial division; approximately 1 kc vernier dial divisions; Both main dial and vernier adjustable for calibration purposes.

SENSITIVITY: Less than 1/2 microvolt for 10 db signal to noise.

AVC: Amplified, delayed AVC having .75 sec or .025 sec discharge; less than 100 microsecond charge.

AUDIO OUTPUT: One watt maximum, .2 watt at AVC threshold.

AUDIO DISTORTION: Less than 3% harmonic, less than 1/2 % intermodulation.

TUBES: 6BZ6 RF Amplifier; 6U8 crystal controlled 1st mixer; 6BE6 VFO controlled 2nd converter; 6BE6 fixed frequency 3rd converter; 6BA6 50 kc IF amplifier; 6BE6 Product Detector and BFO; 8BN8 1st audio amplifier, bias rectifier and AM noise limiter; 6AQ5 audio output; 6BF6 AVC Amplifier-Diode detector-and AVC rectifier; 6X4 Rectifier.

POWER CONSUMPTION: 40 watts, 120/240 volts 50/60 cycle AC

DIMENSIONS: 12" wide X 7" high X 9" deep.

WEIGHT: 14.5 pounds.

II. INSTALLATION

POWER REQUIREMENTS -

The Drake 2-B is designed for 120 volt 50/60 cycle AC only and consumes 40 watts. If desired it can be connected for 240 volt operation. See schematic diagram for details.

AUDIO OUTPUT -

A good quality permanent magnet 4 ohm speaker should be connected to terminals marked SPKR and GND on the rear of the chassis. Accessory speaker model 2AS is available from your supplier and provides a good match, correct tone range for good communications audio, and compatible appearance with your new receiver.

ANTENNA -

The antenna input impedance of the 2-B is 50 to 75 ohms. The terminal marked ANT should be connected to the inside conductor of a coax line and the shield connected to the GND terminal. A cutout is also provided for installation of a coax type connector if desired. This should be internally connected to the ANT terminal if used.

It is recommended that when the 2-B is used with a transmitter, the transmitting antenna be used, changeover being accomplished by an antenna relay.

MUTING -

While a normal standby-receive switch is provided on the front panel, much smoother station operation can be had by the use of an external muting relay controlled by the transmitter. Connect the inner wire of a shielded cable to the MUTE terminal and the shield to a GND terminal. The inner conductor should be connected to a relay contact either in the transmitter or antenna relay which is normally open when transmitting and grounded when receiving. Connect the shield of the mute wire to ground at the relay. When using this external control, the panel switch should be left in the STBY position.

If a voice controlled transmitter is used, this external muting is essential and it will be found very convenient in manually operated installations.

ANTI-TRIP -

In the case of voice controlled transmitters it is also necessary to connect the SPKR and GND terminals to the exciter terminals designated for antitrip control. The impedance of the audio output is 4 ohms. If the transmitter manufacturer recommends a higher impedance for connection to his antitrip circuit, it may be necessary to use a 4 to 500 ohm line matching transformer. Connect the SPKR and GND terminals to the 4 ohm winding and the transmitter antitrip terminals to the 500 ohm winding.

III. OPERATION

A brief outline of recommend control settings will be given for each mode of transmissions, followed by a more detailed explanation of the function of each control.

A. AM RECEPTION -

| <u>Switch name:</u> | <u>Set to:</u> |
|---------------------|---|
| <u>POWER-OFF</u> | <u>POWER</u> |
| <u>STBY-RCV</u> | <u>RCV</u> (STBY if using external muting) |
| <u>S.AVC-F.AVC</u> | <u>S.AVC</u> |
| <u>NL-OFF</u> | <u>OFF</u> (NL if excessive noise is present) |
| <u>PROD-DIODE</u> | <u>DIODE</u> |
| <u>BFO-OFF</u> | <u>OFF</u> |

Turn BANDSWITCH to desired band.
Set PRESELECTOR to desired band.
Set RF GAIN fully clockwise.
Set PASSBAND selector switch to 3.6 (2.1 if bad QRM exists)
Adjust PASSBAND tuning to center of longest range.
Tune in signal with main tuning dial and then carefully peak PRESELECTOR.

B. CW RECEPTION -

| <u>Switch name:</u> | <u>Set to:</u> |
|---------------------|---|
| <u>POWER-OFF</u> | <u>POWER</u> |
| <u>STBY-RCV</u> | <u>RCV</u> (STBY if using external muting) |
| <u>S.AVC-F.AVC</u> | <u>S.AVC</u> (F.AVC if break in operation is desired) |
| <u>NL-OFF</u> | <u>OFF</u> (Noise limiter works on diode detector only) |
| <u>PROD-DIODE</u> | <u>PROD</u> |
| <u>BFO-OFF</u> | <u>BFO</u> |

Turn BANDSWITCH to desired band.
Set PRESELECTOR to desired band.
Set R.F. GAIN fully clockwise.
Set PASSBAND selector switch to .5 KC
Set PASSBAND tuning knob to the small dot at either end of shortest line.
Tune in signal with main tuning dial and then carefully peak PRESELECTOR.
Set AF GAIN as required.
PASSBAND tuning can now be readjusted for minimum interference and maximum signal strength of desired signal.
If AVC action is not desired, back off R.F.GAIN until meter just stops kicking.

C. SINGLE SIDEBAND OR DOUBLE SIDEBAND SUPPRESSED CARRIER RECEPTION -

| <u>Switch name:</u> | <u>Set to:</u> |
|---------------------|---|
| <u>POWER-OFF</u> | <u>POWER</u> |
| <u>STBY-RCV</u> | <u>RCV</u> (STBY if using external muting) |
| <u>S.AVC-F.AVC</u> | <u>S.AVC</u> |
| <u>NL-OFF</u> | <u>OFF</u> (Noise limiter works on diode detector only) |
| <u>PROD-DIODE</u> | <u>PROD</u> |
| <u>BFO-OFF</u> | <u>BFO</u> |

Turn BANDSWITCH to desired band.
Set PRESELECTOR to desired band.
Set R.F.GAIN fully clockwise.
Set PASSBAND selector at 2.1 KC
Set PASSBAND tuning knob to the dot at the end of the medium length line which corresponds to the desired sideband.
Tune in signal carefully for natural voice quality.
Peak PRESELECTOR carefully.
Adjust A.F.GAIN as required.

ALTERNATIVE METHODS:

While the preceding are the recommended settings for normal operation, the receiver is designed to allow the individual operator to select a wide variety of receiver characteristics to meet his need of the moment. It is possible to vary AVC time constants, band width, and type of detector independently, permitting many combinations - one of which should meet his requirement.

Some samples of combinations differing from those first recommended will be discussed to show both their advantages and disadvantages.

For AM reception the diode detector and 3.6 KC passband selectivity are favored for normal use but under crowded band conditions the narrower 2.1 KC bandwidth may be more desirable. Tuning becomes more critical using the 2.1 KC position. Tune for pleasing voice quality. This will not correspond with maximum S meter reading. The PASSBAND tuning knob will now function as a fine tuning adjustment and can be used to select the sideband having the least interference.

When listening for weak AM stations, or when QSB is pronounced, better results may be obtained by using the product detector and BFO. The signal to noise ratio will improve and selective fading will practically disappear. Set the PASSBAND tuning knob to either dot at end of the medium length line, with the PASSBAND selectivity at 2.1. Switch on the BFO and carefully zero beat the carrier. Then set the detector switch to PROD. Without touching the main tuning dial, adjust the PASSBAND tuning for best voice quality and least interference. If adjacent channel interference is severe, try the other sideband. This may be accomplished by turning the PASSBAND tuning knob to the opposite dot. Tuning will be critical and drifting or frequency modulation of the transmitting station may cause trouble.

For CW reception the .5 KC PASSBAND selectivity is best. Either detector can be used but the product detector is superior since fading will be reduced as well as intermodulation. Use of the product detector permits the AVC to be used, which can prove very useful - especially when fading conditions are prevalent.

Experimentation with the AVC may prove useful. It offers the advantage of reducing QSB, provides more uniform level for net operation, and allows use of the S-meter.

For "break-in" CW operation fast AVC may be best as recovery time will be virtually instantaneous.

A very useful accessory for the CW and SSB man is a good Q multiplier such as the Drake 2-BQ. A plug for the 2-BQ is provided on the chassis rear. If used on peak, a band pass of as low as 100 cycles at 6 DB down can be achieved. If the null is used, an interfering heterodyne can be rejected.

For reception of Single Sideband and Double Sideband suppressed carrier stations the procedure already listed is by far the best.

In the early days of sideband and on many receivers still on the market, it is customary to back off the RF Gain when listening to sideband. This was due primarily to improper ratio between BFO voltage and signal voltage at the detector. To illustrate the improvement of the product detector over the diode detector, listen to both a strong and a weak signal using the recommended procedure. Then try the same signals using the diode detector with BFO on and RF Gain reduced and AF Gain advanced.

In certain applications it may be desirable to use a still slower AVC discharge time than is provided inside the receiver. This may be accomplished external to the receiver by connecting a capacitor from the AVC terminal to the MUTE terminal on the chassis rear.

D. CONTROLS -

Getting the most from your receiver under the varying conditions encountered in the Ham bands requires a thorough understanding of the proper adjustment of all controls.

The 2-B is a very versatile receiver and as such requires a good many controls. Once they become familiar, they will prove extremely useful and not in the least confusing.

THE SLIDE SWITCHES -

The row of slide switches across the front panel are used to energize or disable the various circuits within the receiver and various accessories which you may wish to add.

Beginning on the left, the POWER-OFF switch controls the AC power to the receiver. The CAL-OFF switch controls B₊ to the 100 KC Crystal Calibrator accessory socket.

The STBY-RCV switch removes ground from the bias line and applies 18 volts negative to all AVC points thus cutting off the receiver. It does not remove B plus from any point. The terminal marked MUTE at rear of chassis is in parallel with this switch to provide for relay control for muting. When an external relay is used, the panel switch should be left in the STBY position.

The next switch is for slow or fast AVC. While this is largely a matter of personal preference, slow AVC is recommended except for "break-in" CW and the few cases in which slow recovery occurs after a strong station charges up the AVC and a very weak station transmits next.

The NL-OFF switch is used to energize a series noise limiter which can be used when the receiver is operated on the diode detector.

The next switch selects either of the two detector circuits. For AM reception the DIODE detector is recommended with the BFO off. For SSB and in most cases for CW the product detector (PROD) is recommended. The product detector will not function with the BFO turned off.

The BFO is switched separately by the last switch. This permits selection of either detector when the BFO is on.

PRESELECTOR DIAL -

The dial in the upper left corner under the meter marked PRESELECTOR tunes the ganged condenser in the grid and plate circuits of the RF stage of the receiver. Careful peaking of this control on all bands is necessary as the tuning will be much sharper than a conventional antenna trimmer. The Ham bands are marked on the dial and a 0 to 10 scale is also provided for tuning any extra bands that may be added.

BAND SWITCH -

On the lower left side is the BAND switch. Ham bands are marked from 80 through 10 meters. Note that the 2nd 10 meter band is the only one supplied as original equipment on the receiver. The other two 10 meter positions and the positions labeled A to E require the addition of auxiliary crystals. See section on Accessories for proper method of setting up these extra bands.

MAIN TUNING DIAL -

The large knob on the right marked FREQUENCY is the main tuning control. This knob tunes the ganged condenser for the variable frequency oscillator and variable IF sections. The dial scale is marked in 10 KC divisions and is adjustable for calibration purposes by sliding left or right with a slight finger pressure on the front of the glass. Note that the dial reads from right to left on 75 meters and the three 10 meter bands and from left to right on the 40, 20, and 15 meter bands. There is also a 0 to 500 logging scale for use on the auxiliary bands.

The skirt on the FREQUENCY knob is marked in 40 subdivisions. Each of these divisions approximate 1 KC on the dial. This skirt may be slipped for calibration purposes by holding the main knob and pushing in slightly on the skirt. By setting the main dial accurately with a crystal calibrator and setting the skirt to agree on one of the long marks, it is possible to read frequency over a limited range with very good accuracy.

R F GAIN -

This control varies the minimum bias on the AVC line and thus controls the gain of both the RF and IF sections of the receiver. In most situations the R F GAIN may be left full on and the AVC allowed to control the receiver. Backing off the control to the point where the S-meter just kicks on peaks can be done without affecting the S-meter accuracy or audio output. At this point or at any point further counterclockwise the AVC is effectively off and volume can be controlled with the R F GAIN control.

PASSBAND -

The passband control is composed of two parts; the passband selector switch and the passband tuning knob.

The selector switch is calibrated with numbers representing the bandwidths in kilocycle at 6 DB down.

The length and position of the lines which make up the passband tuning calibration indicate the relative bandwidths and their positions with respect to each other. The ends of the lines and the dots show respectively approximate 6 and 20 DB down points of the selectivity curves. The pointer of the passband tuning knob represents the relative position of the fixed 50 KC BFO with respect to the movable passbands.

In general, the pointer should be set to the dots of the appropriate passband for receiving SSB and AM by the exalted carrier method but this setting may be changed to suit the taste of the individual operator.

The numbers 1 and 2 over the dots are for the purpose of identifying the sideband being received as noted on the receiver dial scale.

For CW reception on the .5 position, the signal is tuned for the most pleasing note with the frequency knob and is then peaked with the passband tuning knob.

AUDIO GAIN CONTROL -

This is a standard audio gain (AF GAIN) control in the grid circuit of the first audio stage. Listening level should normally be adjusted with this control and not with the RF GAIN.

S METER ZERO -

A hole in the front panel near the BAND switch allows access to the S meter zero control. This should be adjusted with no antenna connected and no signal coming in. Adjust with a small screw driver so that the meter reads one. This setting should not require adjustment unless severe fluctuations in line voltage occur. With an antenna connected, the meter may read up scale somewhat. This is the local noise level and will vary from day to day and band to band. Do not zero out this level or the meter will be very "Scotch".

PHONE JACK -

A phone jack is provided in the lower left corner of the panel for private listening when desired. The jack automatically mutes speaker output when headphones are plugged in. While impedance of phones is not critical and adequate output is available for most commercially available phones, more output is obtained from low impedance phones.

IV. ACCESSORY BANDS

In addition to the high grade ham band reception provided by the 2-B similar performance off the ham bands is readily available merely by purchasing additional crystals for the first converter.

Since band switching in this receiver does not affect any of the circuits following the first conversion, the problem of extended coverage has been greatly simplified.

The unique design of the crystal oscillator stage which employs fundamental crystals on the lower frequencies and overtone crystals above 15 mc makes the switching problem relatively simple. Crystal sockets and front panel switching are provided for up to five additional 600 kc ranges.

Such additional coverage may be desired for covering MARS frequencies, the citizens band, WWV, foreign broadcast or many other applications. The possibility also exists that some amateur allocations may be changed in the future. In such an event coverage would be available on this receiver for the cost of suitable crystals.

The general formula for calculating the crystal frequency needed to cover a given 600 kc band of frequencies is as follows:

$$\text{XTAL} = \text{Lowest desired frequency} + 4.1 \text{ mc.}$$

or

$$\text{XTAL} = \text{Highest desired frequency} - 4.1 \text{ mc.}$$

For example: Find xtal frequency for band coverage of 9.9 to 10.5 mc for receiving WWV. $\text{XTAL} = 9.9 \text{ mc} + 4.1 \text{ mc} = 14 \text{ mc.}$

When using these auxiliary bands, the received frequency can be determined by adding or subtracting the 80 meter dial calibration from the crystal frequency. Whether you add or subtract is determined by the accessory band used and the preselector setting.

For example, assume that the 14.0 mc crystal found by the formula above is inserted in the "C" accessory socket, and the frequency dial was set to 4.0 mc on the 80 meter scale. Adding 4.0 mc to the 14.0 mc crystal frequency gives 18.0 mc and subtracting 4.0 mc from 14.0 mc gives 10.0 mc. Therefore, you know that you are either tuned to 10.0 mc or 18.0 mc.

You will note that the chart on page 13 shows the frequency to which the preselector is tuned on each accessory band. The chart shows that the preselector will tune to 10.0 mc at approximately 4 and to 18.0 mc at approximately 8.

The tables on the following page show crystal frequencies required to obtain coverage on any 600 kc band between 3.9 and 30 mc. As you will note, every crystal adds not only one, but two 600 kc ranges to your 2-B Receiver. This is accomplished by plugging crystal in the proper socket, resetting band switch, and reapeaking preselector. Some crystals such as the 14 mc will provide two ranges without changing crystal socket and band switch. Log sheets showing both frequency ranges, band/crystal socket and preselector settings are supplied with each crystal shipped from the factory.

CHART FOR SELECTING CRYSTALS FOR DRAKE 2-B RECEIVER

| <u>BAND COVERAGE</u> <u>In Mc</u> | <u>BAND SWITCH</u> <u>& xtal socket</u> | <u>BAND COVERAGE</u> <u>In Mc</u> | <u>BAND SWITCH</u> <u>& xtal socket</u> | <u>XTAL NEEDED</u> <u>In Mc</u> |
|--------------------------------------|--|--------------------------------------|--|------------------------------------|
| 3.9 - 4.5 | A | 11.5 - 12.1 | C | 8.0 # |
| 4.5 - 5.1 | A | 12.1 - 12.7 | C | 8.6 # |
| 4.9 - 5.5 | B | 12.5 - 13.1 | C | 9.0 # |
| 5.4 - 6.0 | B | 13.0 - 13.6 | C | 9.5 |
| 5.9 - 6.5 | B | 13.5 - 14.1 | C | 10.0 # |
| 6.4 - 7.0 | B | 14.0 - 14.6 | C | 10.5 |
| 6.9 - 7.5 | 40 | 14.5 - 15.1 | C | 11.0 * |
| 7.4 - 8.0 | B | 15.0 - 15.6 | C | 11.5 # |
| 7.9 - 8.5 | B | 15.5 - 16.1 | C | 12.0 # |
| 8.4 - 9.0 | B | 16.0 - 16.6 | C | 12.5 |
| 8.9 - 9.5 | B | 16.5 - 17.1 | D | 13.0 |
| 9.4 - 10.0 | B | 17.0 - 17.6 | D | 13.5 # |
| 9.9 - 10.5 | C | 17.5 - 18.0 | D | 14.0 # |
| 10.4 - 11.0 | C | 18.0 - 18.6 | D | 14.5 |
| 10.9 - 11.5 | C | 18.5 - 19.1 | D | 15.0 |
| 11.5 - 12.1 | C | 19.1 - 19.7 | D | 15.6 # |

Following are Third Overtone for "E" Band except as noted.

| | | | | |
|-------------|----|-------------|-----------------|--------|
| 13.9 - 14.5 | 20 | 21.5 - 22.1 | | 18.0* |
| 14.9 - 15.5 | | 22.5 - 23.1 | | 19.0 |
| 15.4 - 16.0 | | 23.0 - 23.6 | | 19.5 |
| 15.9 - 16.5 | | 23.5 - 24.1 | | 20.0 |
| 16.4 - 17.0 | | 24.0 - 24.6 | | 20.5 |
| 16.9 - 17.5 | | 24.5 - 25.1 | | 21.0 |
| 17.4 - 18.0 | | 25.0 - 25.6 | | 21.5 |
| 17.9 - 18.5 | | 25.5 - 26.1 | | 22.0 # |
| 18.4 - 19.0 | | 26.0 - 26.6 | | 22.5 |
| 18.9 - 19.5 | | 26.5 - 27.1 | | 23.0 |
| 19.3 - 19.9 | | 26.9 - 27.5 | | 23.4 # |
| 19.9 - 20.5 | | 27.5 - 28.1 | | 24.0 |
| 20.4 - 21.0 | | 28.0 - 28.5 | 10 ₁ | 24.5 # |
| 20.9 - 21.5 | 15 | 28.5 - 29.1 | 10 ₂ | 25.0 * |
| 21.5 - 22.1 | | 29.1 - 29.6 | 10 ₃ | 25.6 # |
| 21.9 - 22.5 | | 29.5 - 30.0 | | 26.0 |

* These three (3) crystals supplied with 2-B for 40, 20, 15 and middle range of 10 meter bands.

These crystals available from factory stock. All others must be special ordered, requiring normally ten (10) days for shipment. All crystals \$5.00 amateur net. We accept orders direct from 2-B users for accessory crystals and replacement parts only, or you may order from our Authorized Distributors.

As you will note, every crystal adds not only one, but two 600 kc ranges to your 2-B frequency coverage. This is accomplished by plugging crystal in proper socket. Log sheets showing both frequency ranges, band/crystal socket, and preselector setting are supplied with each accessory crystal.

When using overtone crystals, it is necessary to tune the E BAND XTAL COIL to resonance at the crystal overtone frequency. This adjustment is accessible from the rear of the chassis. To tune this coil, plug crystal to be used into socket E. Attach a VTVM between ground and the test point, on top of the chassis just in front of the crystal socket. Set bandswitch on 80 meters and VTVM to the lowest DC range. Zero the VTVM and switch receiver bandswitch to E. Adjust the E band coil for maximum indicated negative voltage.

Popular frequency crystals for Citizen Band, Shortwave Broadcast Bands WWV, MARS, and 10-meter Amateur Band are as follows:

| | |
|---------|---|
| 8.0 mc | 25 meter SW Broadcast and MARS 3.9 to 4.5 mc |
| 8.6 mc | 5 mc WWV and 61 meter SW Broadcast |
| 10.0 mc | 49 meter SW Broadcast |
| 11.5 mc | MARS 7.4 to 8 mc and 19 meter SW Broadcast |
| 13.5 mc | 10 mc WWV and 31 meter Shortwave Broadcast |
| 14.0 mc | 10 mc WWV and 17 meter Shortwave Broadcast |
| 22.0 mc | 11 meter Shortwave Broadcast |
| 23.4 mc | Citizens Band |
| 24.5 mc | 10 meters 28.0 to 28.6 mc |
| 25.6 mc | 10 meters 29.1 to 29.7 mc and 13 meter SW Broadcast |

The chart on the following page shows the coverage of the preselector for each of the auxillary bands. Solid lines show the preferred coverage for each band while the dashed lines show limits of possible coverage. Extending the range into the dashed area will result in some change of gain as the tuned circuits will not present the correct LC ratio.

The log scale charts which follow are a handy means of recording the dial readings for any crystals added to the receiver. Two sample charts have been filled out for crystals that may prove popular and blank charts are provided for additional crystals.

BAND

Solid line indicates recommended range for each band

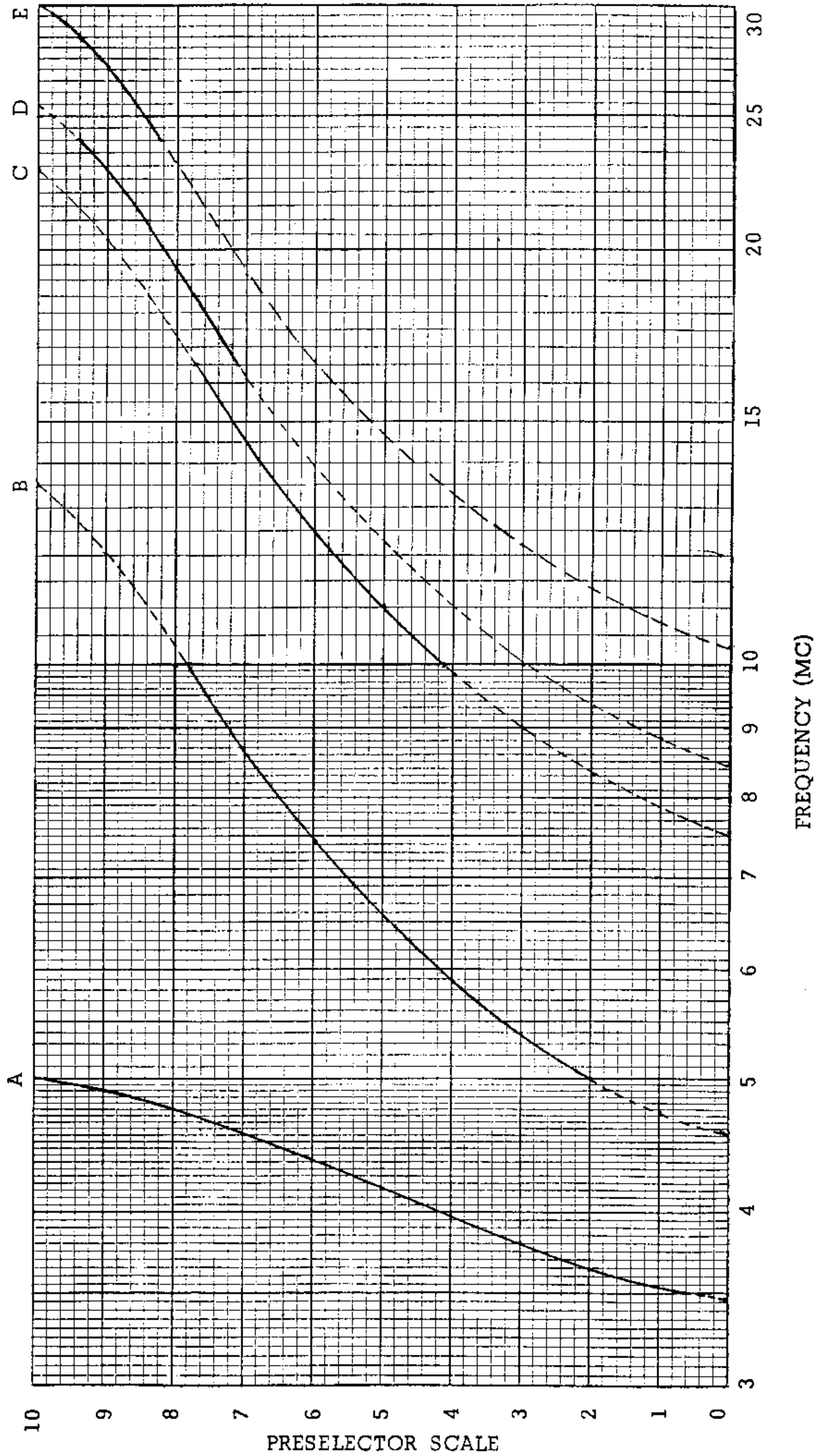

Coverage - WWV (10 mc) and 17 meter Shortwave Broadcast

Crystal Freq. - 14.0 mc. Band/Crystal socket - C

| | Log Scale | | | | | | |
|-------------|-----------|------|------|------|------|------|------|
| | 500 | 400 | 300 | 200 | 100 | 0 | -100 |
| Preselector | Freq. Mc. | | | | | | |
| 4 | 10.5 | 10.4 | 10.3 | 10.2 | 10.1 | 10.0 | 9.9 |
| 8.5 | 17.5 | 17.6 | 17.7 | 17.8 | 17.9 | 18.0 | 18.1 |

Coverage - Citizens Band and 19.3 - 19.9 mc.

Crystal Freq. - 23.4 mc. Band/Crystal socket - E

| | Log Scale | | | | | | |
|-------------|-----------|------|------|------|------|------|------|
| | 500 | 400 | 300 | 200 | 100 | 0 | -100 |
| Preselector | Freq. Mc. | | | | | | |
| 9 | 26.9 | 27.0 | 27.1 | 27.2 | 27.3 | 27.4 | 27.5 |
| 7 | 19.9 | 19.8 | 19.7 | 19.6 | 19.5 | 19.4 | 19.3 |

Coverage - _____

Crystal Freq. - _____ Band/Crystal socket - _____

| | Log Scale | | | | | | |
|-------------|-----------|-----|-----|-----|-----|---|------|
| | 500 | 400 | 300 | 200 | 100 | 0 | -100 |
| Preselector | Freq. Mc. | | | | | | |
| | | | | | | | |
| | | | | | | | |

Coverage _____

Crystal Freq. _____ Band/Crystal socket _____

| | | Log Scale | | | | | | |
|-------------|-----------|-----------|-----|-----|-----|-----|---|------|
| | | 500 | 400 | 300 | 200 | 100 | 0 | -100 |
| Preselector | Freq. Mc. | | | | | | | |
| | | | | | | | | |
| | | | | | | | | |

Coverage _____

Crystal Freq. _____ Band/Crystal socket _____

| | | Log Scale | | | | | | |
|-------------|-----------|-----------|-----|-----|-----|-----|---|------|
| | | 500 | 400 | 300 | 200 | 100 | 0 | -100 |
| Preselector | Freq. Mc. | | | | | | | |
| | | | | | | | | |
| | | | | | | | | |

Coverage _____

Crystal Freq. _____ Band/Crystal socket _____

| | | Log Scale | | | | | | |
|-------------|-----------|-----------|-----|-----|-----|-----|---|------|
| | | 500 | 400 | 300 | 200 | 100 | 0 | -100 |
| Preselector | Freq. Mc. | | | | | | | |
| | | | | | | | | |
| | | | | | | | | |

V. CIRCUIT THEORY

RF AMPLIFIER -

A 6BZ6 is used as a straight RF amplifier on all bands. This is a semi-remote cutoff pentode having high gain, low intermodulation, and excellent control characteristics. The antenna terminal is connected to the primary of the antenna coil which is designed for 50 to 75 ohms unbalanced input. The secondary of the antenna coil and the plate circuit coil primary are tuned to resonance on the forty meter and "B" bands by the ganged capacitors C-3A and C-3B. This capacitor is tuned from the front panel and marked PRESELECTOR.

The preselector is made to tune the other ten bands by switching, with the band switch, capacitance or inductance shunts across the antenna coil secondary and the RF plate coil primary as needed to raise or lower their resonance. The shunts are selected so that the preselector will cover continuously frequencies from 3.5 to 30 mc.

Output of the RF plate coil secondary is coupled to grid one of the 6U8, the first mixer.

Sufficient gain is available in the RF Section to assure that the front end noise will blanket noise from succeeding mixer stages. AVC is applied to the signal grid of the 6BZ6 through R4.

The S-meter is connected in a bridge circuit between the plates of the RF and IF tubes and the remainder of the B plus load in the receiver. A potentiometer is used to balance the bridge under no signal conditions. Any change in current in the RF amplifier is reflected by the S-meter providing good indication of received signal strength. Note that the minimum reading on the meter is S-1, not zero. Signals below 1/2 microvolt at the antenna terminal will not activate the AVC system nor read on the meter due to AVC delay. The meter scale is logarithmic and each S unit represents an increase in signal strength of 5 DB. The S-METER CALIBRATE provision is a screw driver adjustment located on the rear of the chassis. It is factory adjusted so that 30,000 microvolts equals 60 DB over S9. This can be approximated in the field by setting the calibrator signal on 80 meters to 20 DB over S-9. (No antenna).

CRYSTAL OSCILLATOR

The triode section of V2, a 6U8, is used in a unique crystal oscillator circuit. For fundamental crystals used in the frequency range from 4 to 20 mc. the circuit is a Pierce Oscillator requiring no tuned inductance. This permits use of any crystal frequency in this range in the auxiliary sockets provided and allows coverage of any 600 kc segment up to 24 mc. For higher frequencies where overtone crystals must be used, the band switch inserts an appropriate coil resonating the circuit on the crystal overtone frequency and the crystal is switched between cathode and a low impedance point of the tuned circuit.

Output from the oscillator is taken from a similar low impedance point and fed through the low end of the RF plate coil secondary to the pentode mixer section of V-2.

HIGH FREQUENCY MIXER -

The pentode section of the 6U8 serves as the first mixer on all bands except 80 meters where it is used as a second RF amplifier. The plate circuit of this tube is tuned from 3500 to 4100 kc on all bands. On 80 meters the RF section is tuning the same range and the tube provides further amplification and selectivity. On other bands the output of the crystal oscillator is introduced together with the RF signal and the tube functions as a mixer with output between 3500 and 4100 kc on all bands. The output circuit is a coupling network tuned by C-11, C-12, C-13, and one section of the main tuning condenser. This unusual coupler provides a low pass filter that assists in the attenuation of spurious responses common to many multiconversion receivers.

The very low noise characteristics of the 6U8 permit this stage to operate at low gain without degrading the signal to noise ratio achieved in the RF stage. AVC voltage is applied to the tube through R-7.

VFO-2ND MIXER -

A 6BE6 is used as the second mixer and variable frequency oscillator with a tuning range of 3955 to 4555 KC. The same range is tuned on all bands giving uniform tuning rate throughout and contributing to the excellent stability of the receiver. Other factors contributing to the high stability of this oscillator are the use of high quality components and careful selection of operating conditions. The high-Q oscillator coil is space wound on a ceramic form. The tuning condenser is of special design using copper plates, soldered construction, and double spacing to provide good stability over a wide temperature range. The frequency of the oscillator is virtually unaffected by changes in tube capacity or by voltage fluctuations.

Output from the first mixer is fed to grid 3 of this tube from the coupler, T-1. The two signals combine producing a difference frequency of 455 kc in the plate circuit tuned by a High-Q I.F. can, T-2. Access to this 455 kc signal for use of a Q-Multiplier or similar device is available at the accessory plug on the rear of the chassis.

3RD CONVERTER

Another 6BE6 is used to convert the 455 kc signal to the 50 kc I.F. frequency. The oscillator section of this tube is fix-tuned to 405 kc. The signal from the preceding stage is fed to grid 3 from the secondary of the 455 kc I.F. can and the plate circuit is tuned to the difference frequency by the 50 kc sideband filter.

PASSBAND TUNER - SELECTOR

The passband tuner-selector consists of 4 tuned circuits of very high Q tuned to the same frequency. This frequency can be shifted from about 47 to 53 kcs by means of permeability tuning controlled by the passband tuning knob on the front panel. This shift is accomplished without altering the shape of the passbands. The passband selector switch varies the coupling between the tuned circuits to provide 3 steep sided selectivity curves. The bandwidths of these curves are .5 KC at 6 DB down - 2.75 KC at 60 DB down, 2.1 KC at 6 DB down - 7.5 KC at 60 DB down, and 3.6 KC at 6 DB down - 10.5 KC at 60 DB down.

I.F. AMPLIFIER -

The output of the 50 kc filter is coupled to V-5, a 6BA6, for further amplification. This stage is a straightforward I.F. amplifier tuned by L-12 and C-42. The AVC applied to this amplifier has very fast attack and release time and serves a function similar to that of a noise limiter. Output of the I.F. amplifier is fed to both V-6 and V-7.

PRODUCT DETECTOR and AUDIO FILTER

V-7 is used as a low distortion product detector for Single Sideband and CW reception. The 50 kc oscillator section provides extremely stable BFO injection voltage having the necessary amplitude for proper mixing with the signal from the I.F. stage. This BFO is provided with separate switching so that it may be used with either detector for CW reception. The incoming signal from the I.F. amplifier is capacitively coupled to grid 3 of the product detector. Heterodyning action similar to any mixer stage produces the audio output. This type of detection greatly reduces both intermodulation and harmonic distortion.

The output from the product detector is fed through a low-pass filter, having a cutoff at 3 kc, to the audio amplifier. The filter removes any 50 kc voltage from the audio and adds to the overall selectivity of the receiver by restricting high audio frequencies.

DIODE DETECTOR and NOISE LIMITER

One diode section of the 6BF6 is used to provide a conventional diode detector for amplitude modulation. The output of either detector may be fed to the audio gain control through the front panel switch. A diode section of the 8BN8 is used as a series noise limiter circuit which may be used in conjunction with the diode detector to provide increased readability under adverse noise conditions. This feature is controlled by the NL-OFF switch located on the front panel.

AUDIO AMPLIFIER -

V-8 is a conventional triode audio amplifier with a gain control in the grid circuit. Negative feedback from the output transformer through R-40 to the cathode helps lower distortion.

V-9 is the power output stage delivering a full watt of audio output. The output transformer provides a correct match for 4 ohm speakers at the output terminal on the rear of the chassis. The headphone jack on the front panel disables speaker terminals for private listening.

AVC AMPLIFIER AND RECTIFIER -

V-6, a 6BF6, serves as the AVC amplifier and rectifier and as the Diode Detector. Two separate AVC voltages are supplied to the receiver and the time constant of one may be varied to provide further versatility.

The voltage developed at the diode plate charges C-65 in less than 100 microseconds and this voltage, AVC 1, is used to control the last I.F. amplifier. The same voltage charges C-67 or C-67 plus C-68 through R-47. This provides AVC-2 for the RF and variable I.F. tubes. The discharge path for all of the AVC system is through R-68 and R-48 (the no signal bias adjustment potentiometer) and has a release time of .75 seconds in the slow AVC position and .025 seconds in the fast AVC position of the switch. The much slower discharge in the slow AVC position is required for good Single Sideband reception. The AVC-1 voltage applied to the I.F. amplifier has somewhat the same action as a noise limiter reducing pops and sudden peaks in the output of the receiver.

Further versatility is provided by bringing the AVC line out to the terminal marked AVC on the chassis rear. By connecting a condenser from this terminal to the mute terminal, any desired time constant can be secured. Larger capacities will result in slower AVC action.

The RF GAIN control applies a negative voltage in series with the AVC voltage to limit the maximum sensitivity of the receiver. The minimum value for this bias voltage is adjusted by R-48 which is Factory preset and not normally requiring adjustment. Correct value of this minimum bias is important to prevent overloading the receiver and it should not be reduced to increase the apparent gain of the set.

Muting is accomplished by inserting a cutoff voltage in series with the AVC condenser so that it is not necessary to charge it when muting or to discharge it when the receiver recovers. This permits almost instantaneous muting and recovery.

POWER SUPPLY -

The full wave power supply uses a 6X4. Condenser input is used with a 2 section 100 microfarad capacitor providing economical but quite adequate filtering. Under load the power supply delivers 150 and 130 volts of B plus.

The negative bias supply uses a diode section of the 8BN8. This supply provides 18 volts negative to the RF gain and muting systems. The minimum value of this bias with the RF gain full on is controlled by a 2 meg. pot and should be held at 1.5 volts. (See maintenance section).

The AC line is fused to protect components in case of shorts.

All filaments are in parallel, with ground providing one side of this circuit.

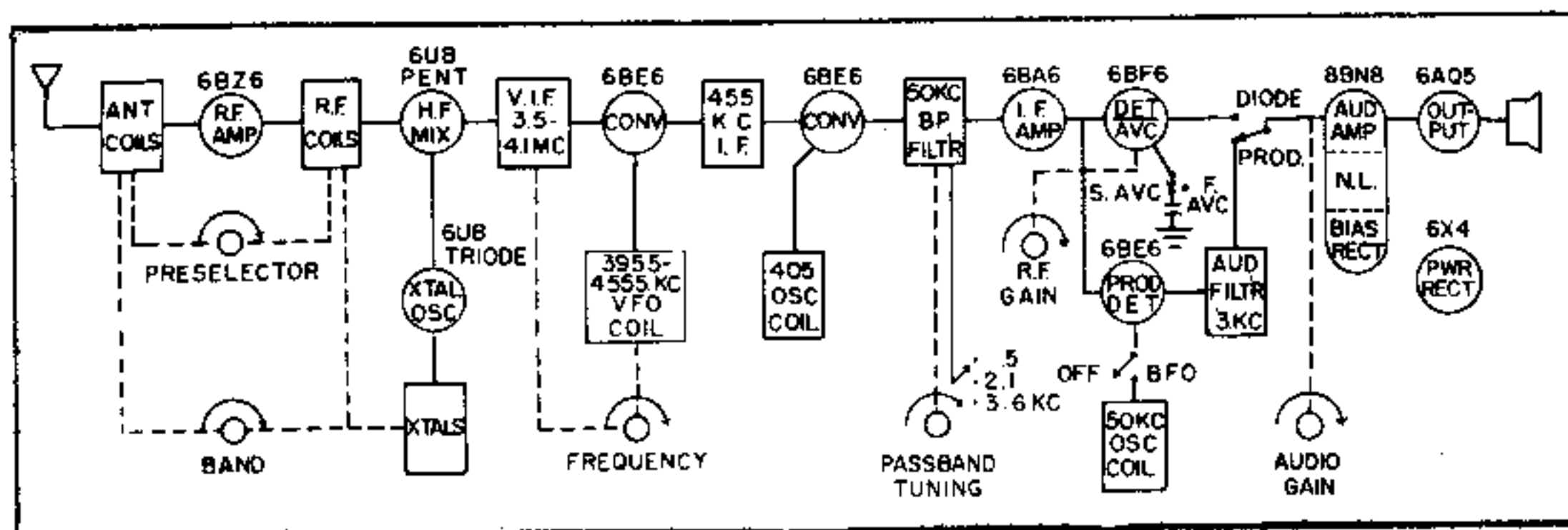
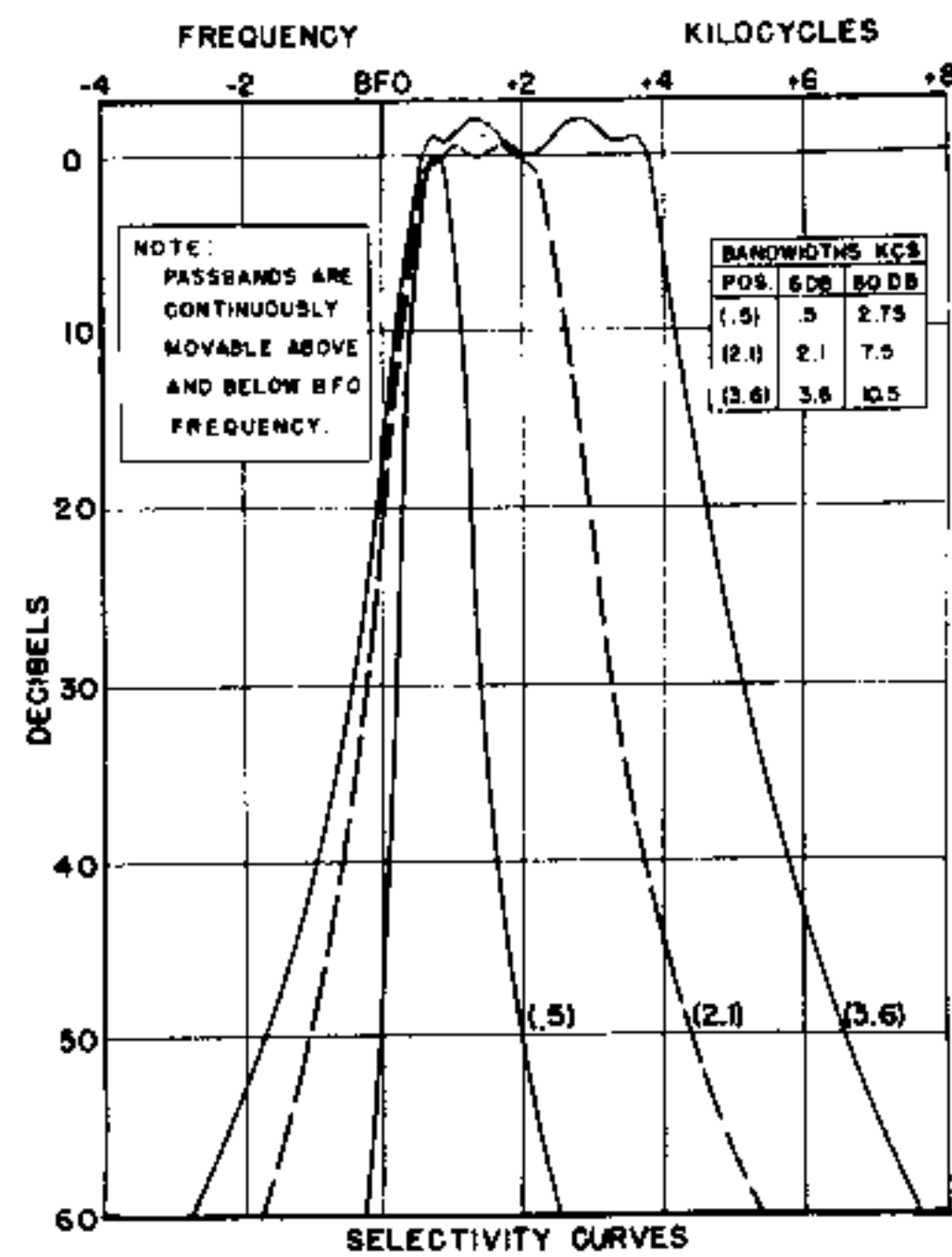

VI. MAINTENANCE

REMOVING SET FROM CABINET -

The set is held in the cabinet by 6 screws on the bottom. To remove the set from cabinet lay set on its face on the knobs and remove these screws and pull the cabinet off the rear of set. This procedure relieves the weight of the chassis on the inside of the cabinet and prevents scratching the paint inside the cabinet. It is not necessary to remove any knobs or disturb the front panel.

TUBE REPLACEMENT -

Most trouble encountered in radio equipment is due to tube failure rather than component failure. The 2-A has been designed so that its tubes may be replaced without need for realignment. The best check on tubes is direct substitution in the receiving set rather than reliance on a tube checker. All tubes are clearly identified on the chassis and care should be taken to put the tubes in the correct sockets.

ALIGNMENT PROCEDURE -

Alignment of the 2-A requires the correct relationship between the various oscillators and should only be done by competent service men with the necessary frequency determining equipment. An accurately calibrated signal generator or frequency meter or a well calibrated separate receiver is necessary. The accuracy attainable with a grid dip meter or similar signal source is not good enough.

A - 50 KC OSCILLATOR -

If an accurate source of 50 kc signal is available it should be fed through a capacitor to pin 1 of V-5, the 6BA6 I.F. amplifier. With the product detector and BFO turned on, adjust slug of T-7 for zero beat.

If a frequency meter or receiver is being used rather than a generator, it should be loosely coupled to pin 7 of V-7 and tuned to the lowest 100 kc point to which it can be set accurately. With the BFO on, the slug of T-7 should be adjusted to produce zero beat of its harmonic on the indicating instrument. A recheck should be made at the next higher 100 kc point on the instrument to be sure the correct harmonic was reached.

B - 405 KC OSCILLATOR -

If a frequency meter or receiver is used, loosely couple to pin 5 of V-4. Set instrument to 810 kc and adjust slug of T-4 for zero beat. (2nd harmonic of 405 kc oscillator.)

If a signal generator is being used, feed into pin 7 of V-4 using a 455 kc signal. This same point is also available at the accessory socket on the chassis rear. Turn the BFO on and use the product detector. Adjust the PASSBAND tuning knob to middle of the range and tune slug of T-4 for zero beat. Move the signal source back to pin 7 of V-3. If no longer zero beat, retune T-4 slightly.

C - 455 KC I.F. CAN -

To align the 455 kc IF can, feed any signal source into the antenna terminal, tune it to zero beat with the receiver, and peak both top and bottom slugs of T-2 for maximum S-meter reading or maximum negative voltage measured with a vacuum tube volt meter at the AVC terminal on the rear of the chassis.

D - VFO ALIGNMENT -

Connect to the ANT terminal a crystal calibrator or signal generator providing outputs at 3600 and 4000 kc. Set band switch to 80 meters and preselector knob to 80. Tune in 3600 kc signal and note dial error. Tune in 4000 kc signal and again note dial error. If both errors are in the same direction, slide dial glass to reduce or compromise error. If error is too great for this minor adjustment, retune to 3600 kc on the dial scale and adjust slug in T-3 for zero beat. Recheck at 4000 kc. Adjust dial to compromise error. Repeat until desired accuracy is achieved.

While it should not be necessary, if the error in tracking the VFO from end to end appears too large to be corrected by the process outlined, changing the value of C-26 (which is selected in production to correct differences in minimum capacity) will correct the end to end error. Adding to this capacity will narrow the spread while reducing it will increase the spread. To repeat, this should only be tried if the condition cannot be corrected by the method suggested earlier.

E - VARIABLE IF ALIGNMENT -

To adjust the Variable I.F. transformer set band switch to 80 meters and connect a generator or calibrator to the ANT terminal. Tune in the signal at 3800 kc. Adjust T-1 for maximum S-meter reading.

F - CRYSTAL OSCILLATOR ALIGNMENT -

On 40, A, B, C, and D bands the crystal oscillator has no circuits requiring alignment. If it is desired to check whether or not the oscillator is operating on any of these bands, place a vacuum tube volt meter on the test point available from the top of the chassis near the 6U8. Set the receiver band-switch to 80 and adjust the voltmeter so that it reads zero when it is set to its lowest range in the DC- position. Now, switch to 40, A, B, C, and D bands. If the crystals in these respective sockets are oscillating, a negative voltage will be observed on the VTVM.

On 20, 15, all 10 meter bands, and band E, the crystal oscillator uses overtone crystals and it is necessary to resonate the coil in the Plate Circuit of the triode section of the 6U8 on this band.

Set the bandswitch on 20 meters. With a VTVM connected and adjusted as above, adjust 20 meter coil for maximum indicated negative voltage. In the same manner, adjust L9 on the 15 meter band and L11 on the E band if used. Check 10 meter bands to be sure they are also oscillating. L9 is used on all 10 meter bands as well as 15 and a small amount of compromise to give uniform oscillation on all of these bands is permissible.

G - PRESELECTOR ALIGNMENT -

NOTE: Field alignment of the preselector should be avoided if possible. Extensive use of increment coil switching is made in the preselector and serious misalignment and tracking error on other bands may occur if the Antenna or RF coils are incorrectly adjusted. If a check on the center of each band shows that the noise with antenna disconnected can be peaked by the preselector tuning knob, further alignment is not warranted.

If front end alignment is deemed absolutely necessary, proceed as follows:

Set band switch to 40 meters. Feed into antenna a signal generator or crystal calibrator at 7200 kc. Tune in signal and peak with preselector tuning control. This point should be at or very near the 40 meter mark on the preselector dial. If not, check pointer to see if it is correctly oriented with the end of shaft rotation. Pointer should read 10 when it is at the clockwise end of rotation. If this is correct, reset the preselector dial to the middle of the 40 meter area and carefully peak L-2 and L-4 for maximum S-meter reading. Move the band switch to the 80 meter band and the generator to 3800 kc. Tune in signal and carefully peak with preselector. While rocking preselector dial peak C-5 for maximum S-meter reading.

Turn band selector switch to the second 10 meter band. Set generator to 28.8 mc. Tune in signal and tune preselector to the middle of the 10 meter area. Adjust L-1 and L-3 for maximum S-meter reading. All other bands are tuned by addition of increment coils to the variable inductances already adjusted; They should require no further alignment.

H - PASSBAND TUNER - SELECTOR CONTROL ADJUSTMENTS -

WARNING: THE PASSBAND TUNER - SELECTOR IS FACTORY ALIGNED AND NO ATTEMPT SHOULD BE MADE TO ADJUST THE SLUGS. THEY ARE ALIGNED IN PRODUCTION, USING SPECIAL TEST EQUIPMENT NOT AVAILABLE COMMERCIALY.

Before checking the passband tuner adjustment, be sure the 50 kc oscillator is exactly on frequency. It is well to check the 405 kc oscillator at this time also.

Using the product detector and the 2:1 kc bandwidth, turn the PASSBAND tuning knob each direction from center while listening to noise. The highest pitch of the noise reached in each direction should be the same. If not, adjust the screw on the back of the passband tuner - selector so that the noise sounds the same pitch at each extreme.

Loosen the set screw on the PASSBAND tuning knob and adjust its position so the noise is the same pitch on each sideband at the normal setting; that is, with the pointer at the dots at the end of the center white line.

TROUBLE SHOOTING -

Charts showing both resistance and voltage readings at all tube sockets appear on pages 28 and 29. This is your best aid in any trouble shooting. Bear in mind that any of these voltages will vary slightly due to line voltage fluctuation and to normal tolerance differences in components.

In the trouble shooting section no attempt has been made to exhaust all possible troubles. The intent is to show a procedure to localize the trouble and to minimize the labor of finding the defect.

By far the majority of trouble encountered will be tube failure. In such cases the best check is direct substitution of a new tube in the set itself. Not all the shortcomings of tubes are observable on a tube checker.

In isolating the trouble the procedure suggested here requires the bare minimum of servicing equipment since it utilizes the set itself whenever possible. If a signal generator and a scope are available, they are of course useful. But the plan outlined here will find most trouble and requires only a reasonably reliable volt-ohmmeter for the job. Systematic signal tracing and switching between alternate circuits in the receiver will lead you to the source of trouble.

Tubes and Dial Lights out: Blown fuse is probable cause. Usually indicates short on the heater string.

Tubes lit but no audio: Check B plus at filter capacitor. If normal, check at pins 5 and 6 of V-9 and pin 7 of V-8. Check headphone jack and leads to speaker. Touch pin 1 of V-8. Should produce hum in speaker. If OK this far, switch detectors. If output from one is OK but not the other, check tube and all voltages in the defective stage.

Audio checks OK but still no output: For troubles in the RF and IF stages you can use the S-meter as well as the audio to observe troubles. Check on several positions of the band switch. If the set works normally on some bands but not on others, the trouble is confined to the preamplifier, either V-1 or V-2.

If its behavior is the same on all bands it may be in either the RF or IF stages. Check the AVC voltage at the terminal on the chassis rear with the AVC switch in the S. AVC position. Check to see if this voltage can be varied by the RF GAIN control. With no signal input it should be variable from about 1.5 to 9 volts as measured on a VTVM. The S-meter should vary in the same direction as this voltage. If the S-meter reads near full scale but the AVC voltage appears normal, check V-5, the 6BA6. If the S-meter is working, this stage probably is also working.

Insert a test lead into the upper right (nearest center) contact of the Q-Multiplier socket on the rear of the chassis. Using this lead as an antenna, you should hear noise. If not, check voltages and resistances of V-4 stage. If the noise does come up at this point, the trouble is in an earlier stage.

If the trouble is nearer the front end of the receiver than V-4, you should be hearing some tube noise even if no signals. While listening to this noise pull V-3 out of the socket. If this stage is operating normally, there should be a marked decrease in the noise. If there is not, investigate voltages in this stage.

If V-3 appeared normal, and the S-meter is following the RF GAIN control but no signals are heard, investigate V-2 and its associated parts. In most cases where the trouble is confined to one or a few bands, V-2 will also be the source of trouble. The crystal oscillator section and its components mounted on the rear deck of the band switch should be checked. However, if the trouble is in the set on the 80 meter band, the crystal section may be eliminated from consideration as there is no crystal operating on this band.

A test lead attached to pin 2 of V-2 should bring in some of the stronger local 80 meter signals if this tube is functioning normally. If the set does work with a lead at this point, trouble must be in V-1. If V-1 is entirely inoperative, the S-meter should read well above its normal no-signal level but may still follow the RF GAIN control. If the S-meter is not reading up-scale but trouble has been isolated to this stage, check components in the grid circuit of this stage.

This stage by stage technique should enable you to isolate the trouble in almost all cases where the receiver is dead. If the complaint is lack of sensitivity though the set is still operative, a similar retracing from the audio back to the front end should be used. Remember that troubles confined to one band must be in either V-1 or V-2.

If the S-meter fails to read with signals but will read with RF GAIN control, check the AVC voltage at the terminal on the chassis rear. If the AVC is not changing with signal level, check L-13. Failure of V-1 or V-5 will cause the S-meter to read high. Failure of V-2, V-3, or V-4 will result in the S-meter reading zero and no signals will be heard. Failure of V-6 or open L-13 results in no AVC voltage but set sounds very hot.

The minimum AVC voltage cannot be measured accurately even with a vacuum tube voltmeter unless the procedure outlined below is followed. This is caused by the fact that the AVC system is a very high impedance. The following procedure should be used to assure correct adjustment of the minimum bias.

Put AVC switch on S. AVC position and connect a VTVM to the AVC terminal on the chassis rear. With the RF GAIN full on (clockwise) and no signal input, adjust R-48 for 1.5 volts on the meter. Carefully zero the S-meter using R-24 which is reached through the small hole in the front panel just above the phone jack. Remove the VTVM and observe change in S-meter reading. Readjust R-48 to return the S-meter to zero. This assures that the bias is now 1.5 volts without the loading effects of the vacuum tube voltmeter.

If trouble with muting is encountered, check voltage at the mute terminal on the chassis rear. This voltage should be zero when listening and approximately nine volts when on standby. When using external muting the front panel switch must be left in the STBY position. External relay should be grounded on receive and open on standby. The sequence of contacts on this relay should be such that the receiver is muted before the transmitter goes on and the transmitter goes off before the receiver muting is removed.

VOLTAGE CHART

| TUBE | TYPE | PIN NUMBER | | | | | | | | |
|------|------|------------|--------|-------|-------|-------|-------|------|-----|-----|
| | | 1 | 2 | 3 | 4 | 5 | 6 | 7 | 8 | 9 |
| V-1 | 6BZ6 | -1.35 | .4 | 0 | 6.3AC | 136 | 60 | 0 | | |
| V-2 | 6U8 | 44 | -1.35 | 100 | 0 | 6.3AC | 137 | 1.2 | .85 | -.1 |
| V-3 | 6BE6 | -.5 | 2.7 | 0 | 6.3AC | 136 | 98 | 0 | | |
| V-4 | 6BE6 | -5.5 | 0 | 0 | 6.3AC | 136 | 52 | -1.4 | | |
| V-5 | 6BA6 | -1.35 | 0 | 6.3AC | 0 | 136 | 80 | 0 | | |
| V-6 | 6BF6 | 0 | 3 | 6.3AC | 0 | -1.4 | 3 | 80 | | |
| V-7 | 6BE6 | -1.7 | 1.1 | 0 | 6.3AC | 50 | 60 | 0 | | |
| V-8 | 8BN8 | -19 | 14.5AC | 3 | 6.3AC | 0 | 2.5 | 47 | -.7 | 0 |
| V-9 | 6AQ5 | NC | 6.2 | 6.3AC | 0 | 150 | 136 | 0 | | |
| V-10 | 6X4 | 149AC | NC | 6.3AC | 0 | NC | 149AC | 152 | | |

NOTE: All measurements made with 11 megohm VTVM and are taken from ground.

Line voltage was maintained at 120 volts 60 cycles.

Switch positions: BFO-on, Prod-Diode in Prod. position, S.-AVC - F.AVC in S.AVC position, R.F. and A.F. gain fully clockwise, Bandswitch in 15 meter position, preselector detuned, Main tuning at 21.15 MC, Bias set at -1.35 volts as measured at AVC terminal, Passband selector in 2.1 KC position with passband tuning knob in the center of the 2.1 KC range, antenna disconnected.

B/1 and B/4 are 152 volts. B/2 is 136 volts, and B/3 is 118 volts.

RESISTANCE TABLE

| TUBE | TYPE | PIN NUMBER | | | | | | | | |
|------|------|------------|------|--------|-----|------|------|------|--------|------|
| | | 1 | 2 | 3 | 4 | 5 | 6 | 7 | 8 | 9 |
| V-1 | 6BZ6 | 3MEG | 150 | 0 | FIL | 26K | 58K | 0 | | |
| V-2 | 6U8 | 52K | 2MEG | 32K | 0 | FIL | 24K | 330 | 320 | 150K |
| V-3 | 6BE6 | 150K | 330 | 0 | FIL | 24K | 30K | 6.8K | | |
| V-4 | 6BE6 | 150K | 1/2 | 0 | FIL | 25K | 35K | 1MEG | | |
| V-5 | 6BA6 | 2MEG | 0 | FIL | 0 | 24K | 22K | 0 | | |
| V-6 | 6BF6 | 25K | 1500 | FIL | 0 | 1MEG | 650K | 44K | | |
| V-7 | 6BE6 | 22K | 220 | 0 | FIL | 73K | 42K | 3300 | | |
| V-8 | 8BN8 | 680K | 10K | 2.5MEG | FIL | 0 | 350K | 370K | 6.8MEG | 19 |
| V-9 | 6AQ5 | NC | 270 | FIL | 0 | 24K | 24K | 680K | | |
| V-10 | 6X4 | 75 | NC | FIL | 0 | NC | 75 | 24K | | |

NOTE: All measurements made to ground with power disconnected.
 Switch positions: BFO switch on, Prod-Diode on Prod., S.AVC - F.AVC switch on S.AVC position,
 R.F. and A.F. gain controls fully clockwise.

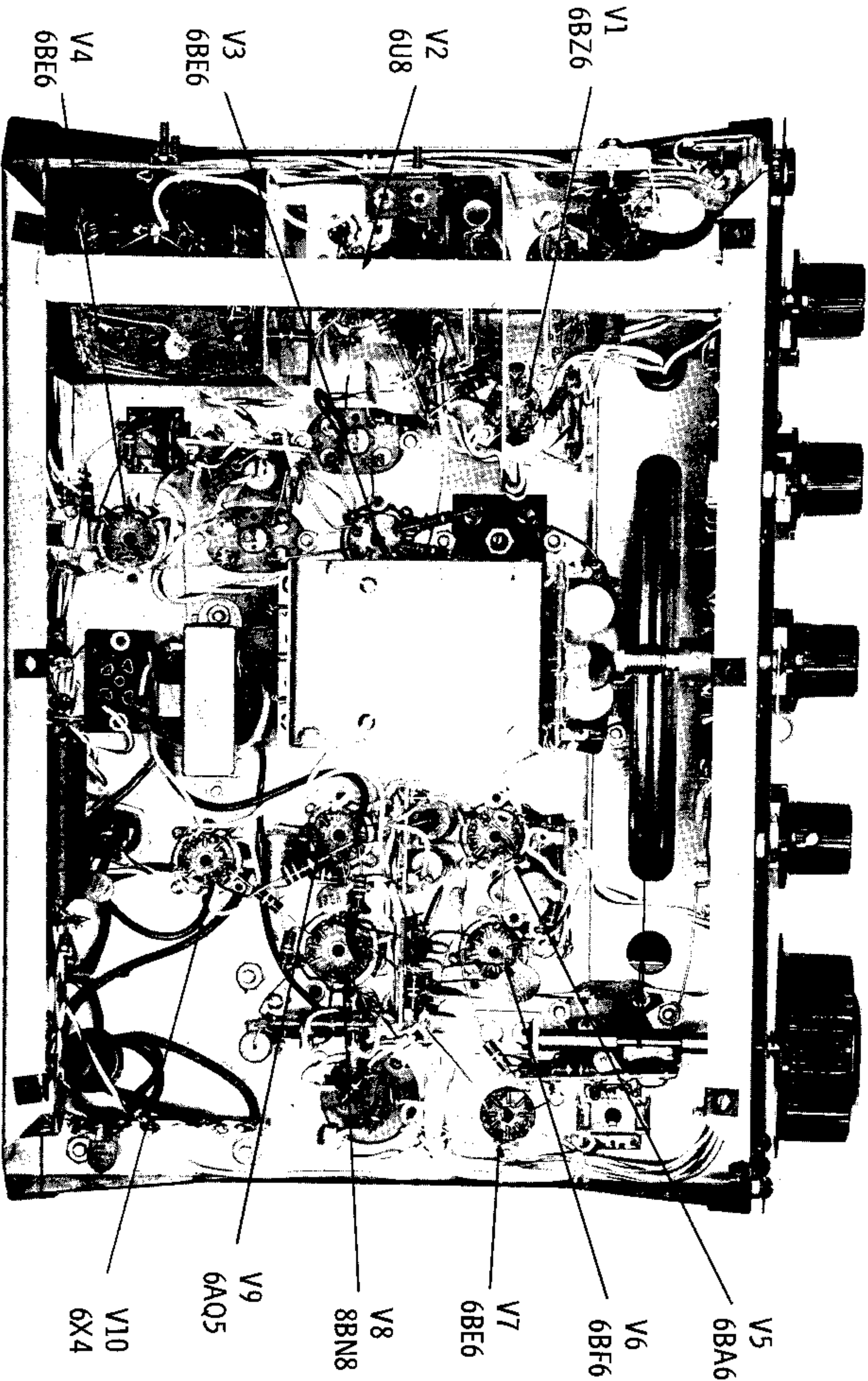

V1
6BZ6

V2
6U8

V3
6BE6

V4
6BE6

V5
6BA6

V6
6BF6

V7
6BE6

V8
8BN8

V9
6AQ5

V10
6X4

6BE6

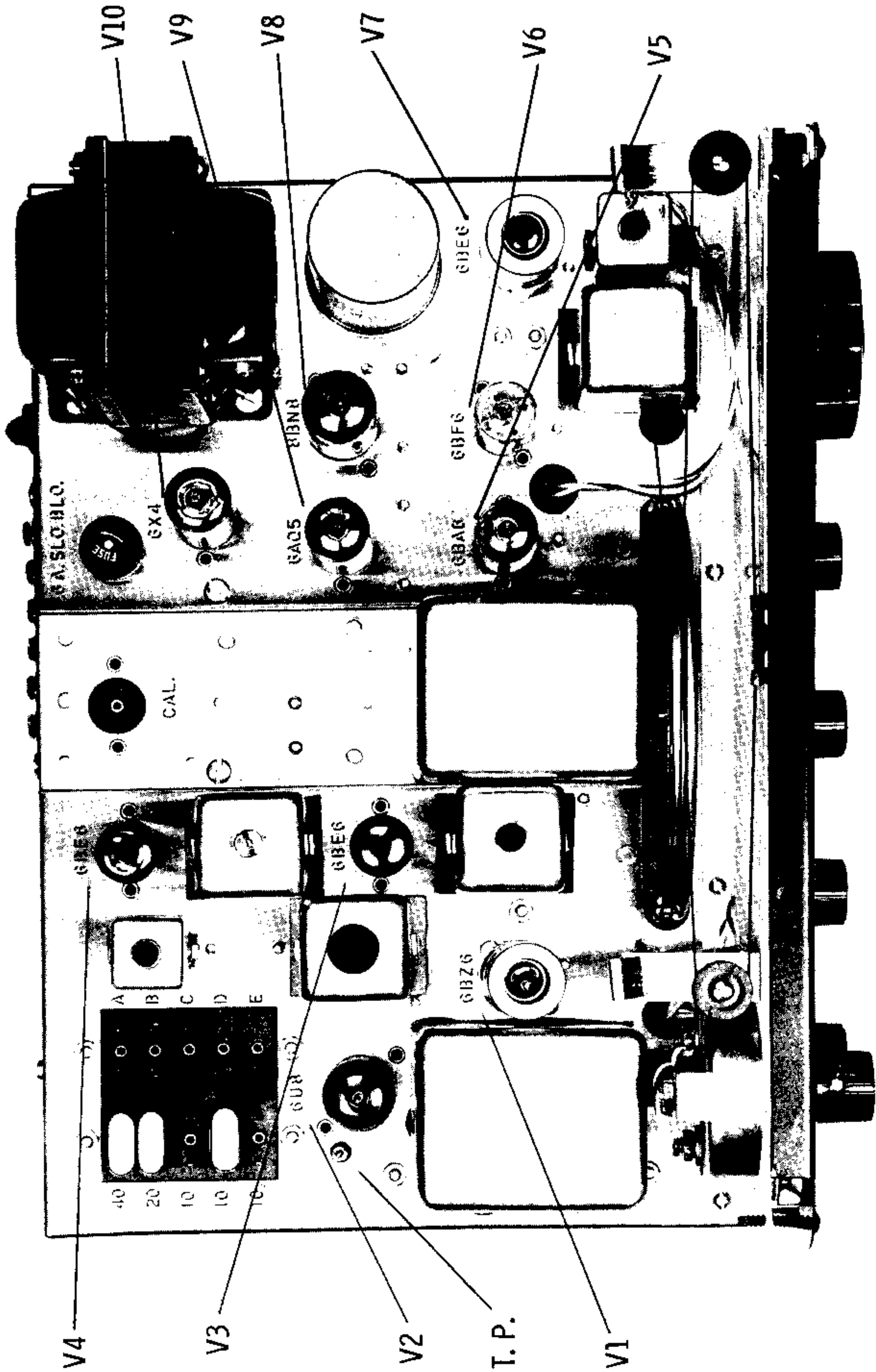

V10

V9

V8

V7

V6

V5

6A5L0/BLO.

FUSE

6X4

6AC5

6BN8

6BAG

6BEG

6BEG

CAL.

6BE8

6BEG

6BZ6

A

B

C

D

E

40

20

10

10

10

6UR

V4

V3

V2

T.P.

V1

2-AC CRYSTAL CALIBRATOR INSTRUCTIONS

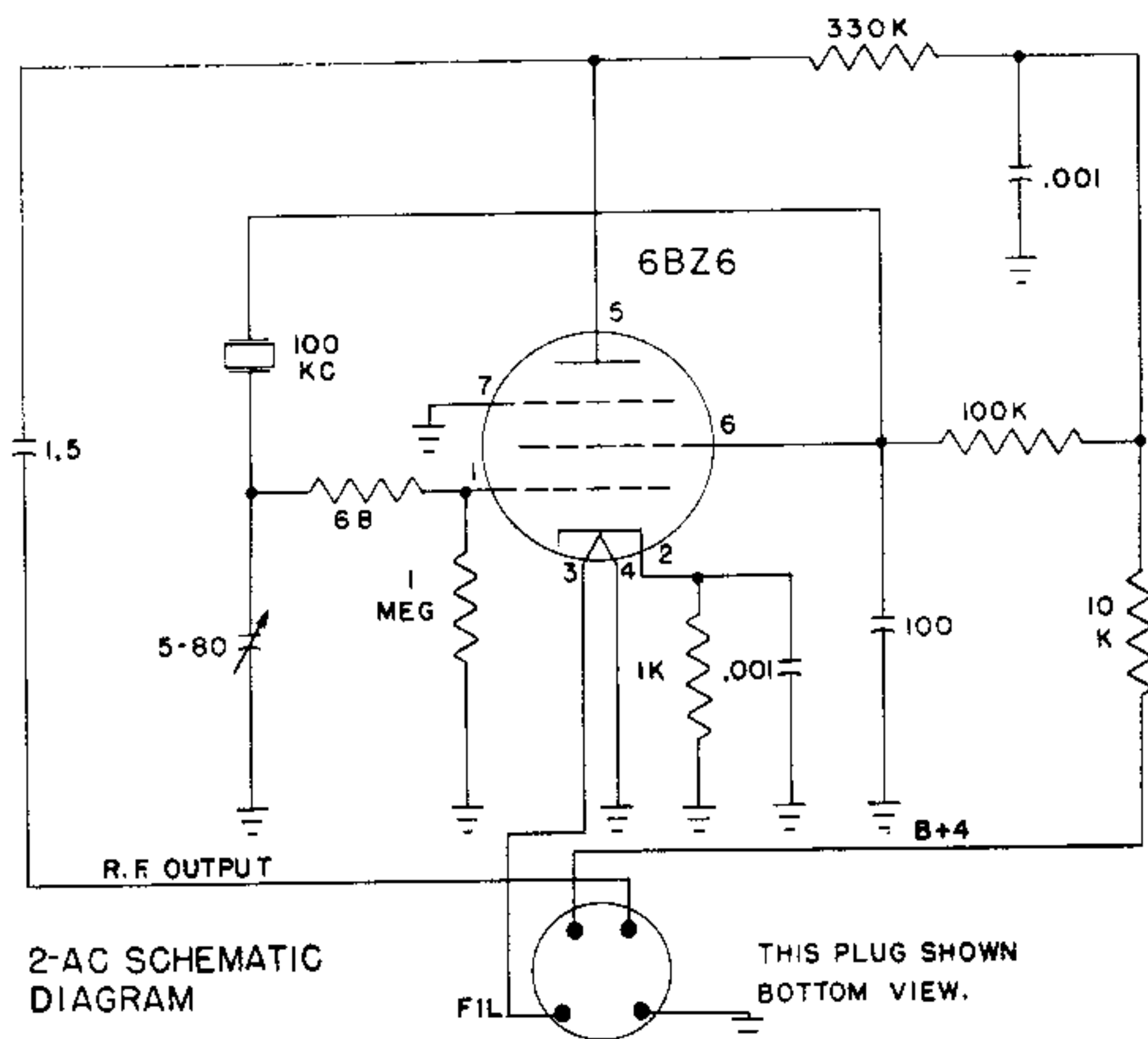

The 100 KC crystal calibrator is an oscillator so designed that it will inject into the receiver a harmonic every 100 KC throughout the receiver's range. This corresponds to the numbered dial divisions on your 2-A or 2-B dial.

To use your 100 KC calibrator, insert it into the socket marked "CAL." which is located at the rear of the receiver chassis. The calibrator is switched on and off by a front panel switch, marked "CAL.-OFF".

To set the receiver dial accurately, turn the "CAL.-OFF" switch to "CAL.", and tune in the 100 KC harmonic nearest the desired operating frequency to zero beat (receiver BFO on). Then slide the dial glass until the pointer lines up exactly with the corresponding dial division.

All 2-AC's are factory aligned, but due to shock and vibration during shipment, additional adjustment is sometimes necessary. To do so, turn on receiver with calibrator on and allow it to warm up for at least thirty minutes. Tune in WWV with the receiver BFO off and "PROD-DIODE" switch on "DIODE". (See page 12, third paragraph of the instruction manual). Make sure that the "CAL.-OFF" switch is in the "CAL." position and carefully adjust the trimmer capacitor located on top of the calibrator chassis to zero beat. This completes all necessary alignment.

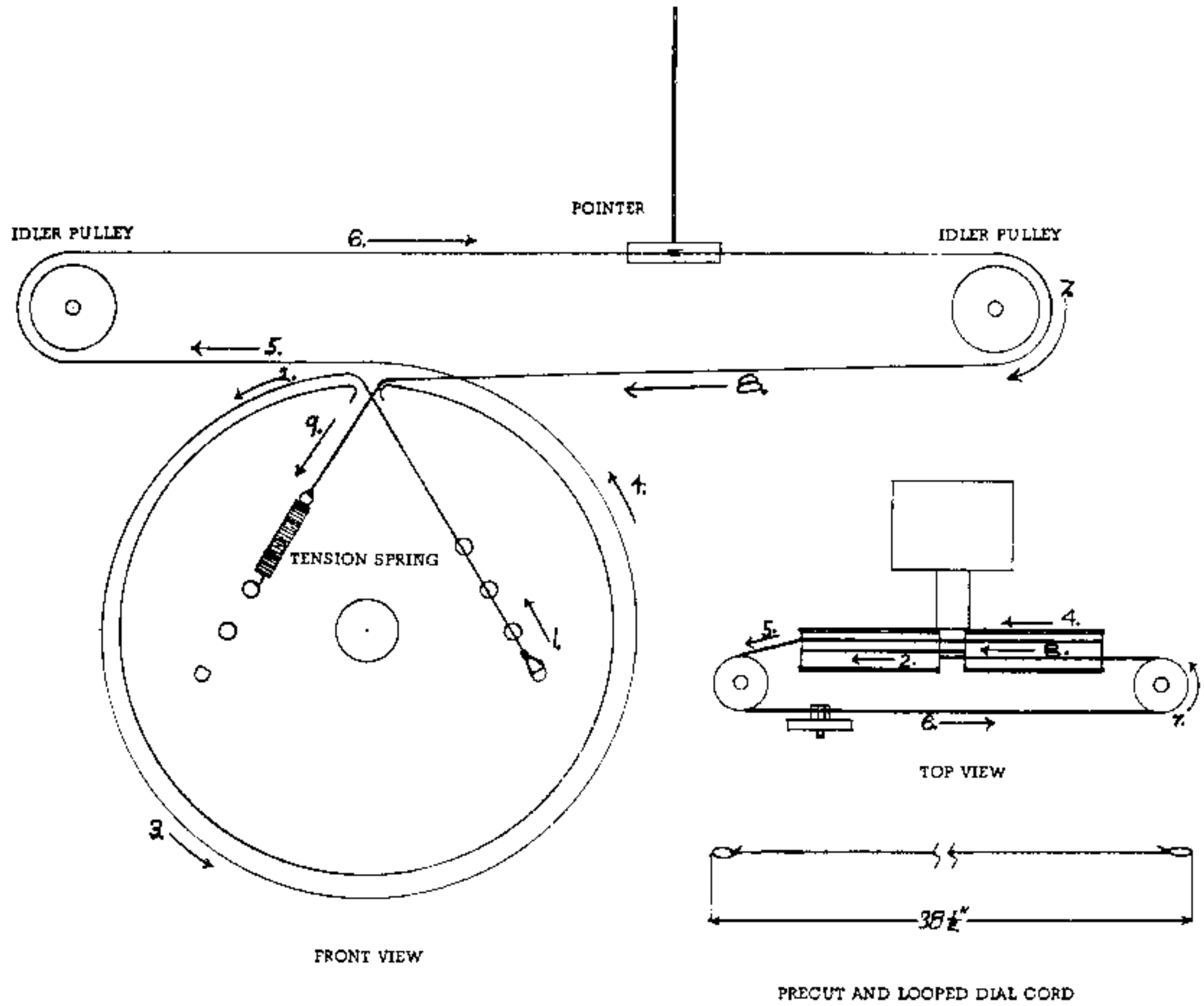

FIG. 1 DIAL POINTER STRINGING

NOTE: Dial pointer stringing should be done to the rear of the drum, and spindle stringing should be done to the front.

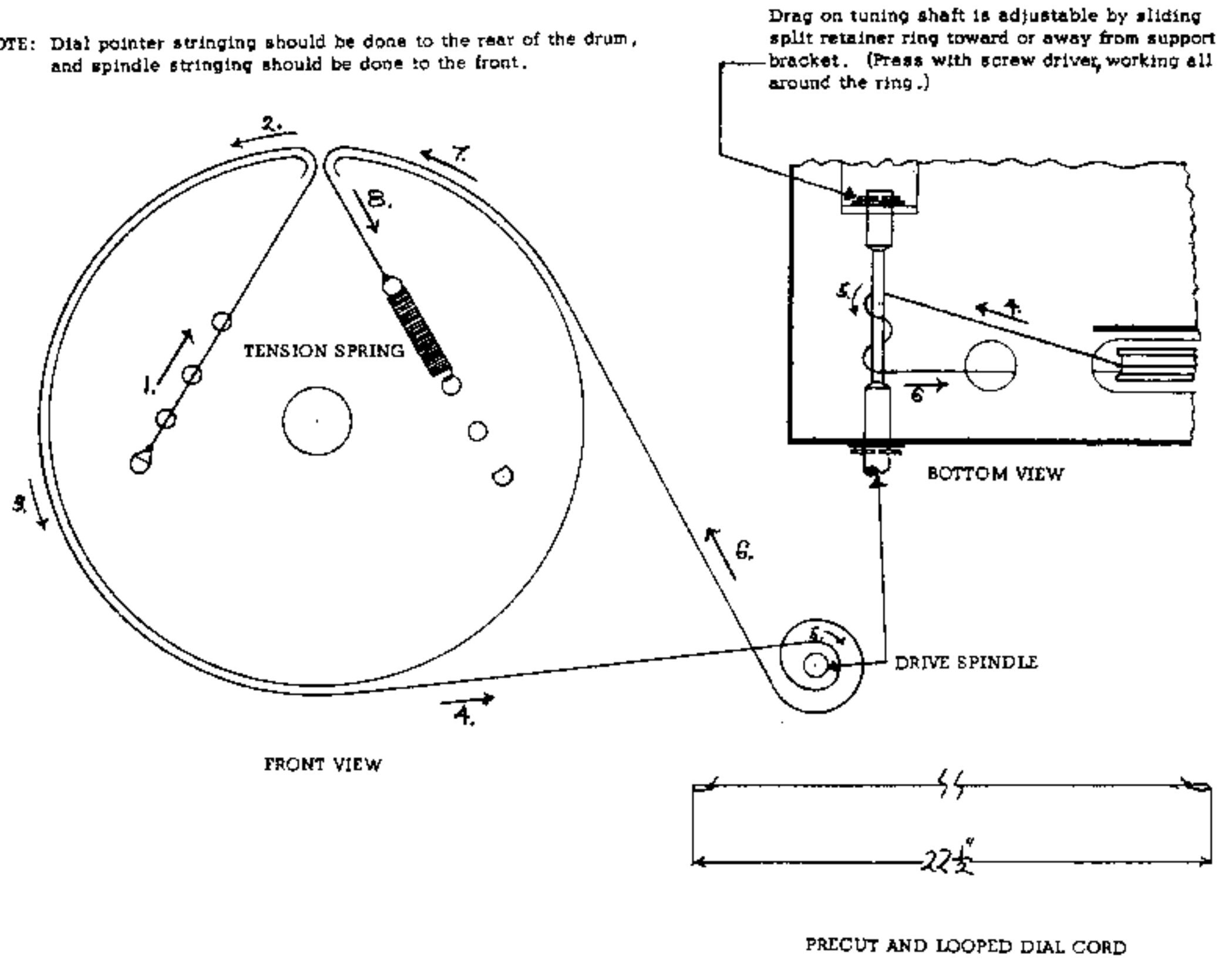

FIG. 2 DRIVE SPINDLE STRINGING

NOTE: Use .025" diameter nylon covered glass dial cord (General Cement 75-A-100 or Walsco 656-R)

PARTS NOT IDENTIFIED ON SCHEMATIC DIAGRAM (2-B)

| | |
|-----------|--|
| T1 | 3.5 - 4.1 MC Variable I.F. transformer |
| T2 | 455 KC I.F. transformer |
| T3 | 3955 - 4555 KC VFO can |
| T4 | 405 KC Oscillator coil |
| T5 | 50 KC Passband tuner - selector |
| T6 | 3 KC Low pass audio filter |
| T7 | 50 KC BFO coil |
| T8 | 5000 ohms to 4 ohms Audio output transformer |
| T9 | Power transformer - 120 V primary, 300 VCT and 6.3 V secondaries |
| | |
| L1 | 10 meter R.F. coil |
| L2 | 40 meter R.F. coil |
| L3 | 10 meter Antenna coil |
| L4 | 40 meter Antenna coil |
| L5 | 15 meter R.F. increment coil |
| L6 | 20 meter R.F. increment coil |
| L7 | 15 meter Antenna increment coil |
| L8 | 20 meter Antenna increment coil |
| L9 | 10 ₃ meter Overtone crystal coil |
| L10 | 20 meter Overtone crystal coil |
| L11 | E band Overtone crystal coil |
| L12 | 50 KC I.F. choke |
| L13 | 50 KC AVC choke |
| L14 | 10 ₂ /15 MC Overtone crystal increment coil |
| L15 | 10 ₁ MC Overtone crystal increment coil |
| | |
| J1 | Crystal calibrator socket (Cinch #2675) |
| J2 | Q-multiplier socket (Cinch #2675) |
| J3 | Main terminal board |
| J4 | Headphone jack |
| | |
| PL1 & PL2 | #47 pilot lamps |

INSTRUCTIONS FOR DRAKE MODEL 2-BQ SPEAKER/Q-MULTIPLIER

Installation with Model 2-B Receiver

1. Plug Q-Multiplier cable into Q-MULT socket on rear of 2-B.
2. Connect speaker leads to screw terminals on 2-B marked SPKR and GND.
3. When the Q-Multiplier is not being used, the PEAK-NOTCH switch should be on NOTCH and the ON-OFF switch should be OFF.

Operating Instructions

Finding the notch setting of the 2-BQ controls for the first time may present a problem. However, practicing with a strong steady carrier such as our 2-AC Crystal Calibrator should enable the operator to obtain good results if the following procedure is carried out.

1. With the 2-BQ switches in the OFF and NOTCH positions, tune in a crystal calibrator signal on the 2-B Receiver.
2. Set the Q-BALANCE control to about 12 o'clock and turn ON-OFF switch to ON.
3. Carefully tune the TUNING knob for a slight null in S-meter reading. It will probably be shallow and rather broad.
4. When the null is found, readjust the Q-BALANCE for further null. Alternately adjusting Q-BALANCE and TUNING controls should produce about 50 db of attenuation.

Notching out a Heterodyne on SSB or AM

1. With the Q-BALANCE control set as described above, turn ON-OFF switch to OFF.
2. Tune in the station you wish to hear in the normal manner as described in the 2-B instruction book.
3. When a heterodyne appears, turn the ON-OFF switch to ON and slowly turn TUNING knob to a position where the heterodyne is eliminated. NOTE: On AM a heterodyne is caused by a beat between desired carrier and an interfering carrier. Removal of either will stop the heterodyne but if you notch out the carrier of the desired signal, the audio will become greatly distorted.
4. If the interfering carrier drifts in frequency, follow it with the Q-Multiplier TUNING; i.e., you tune the receiver for the best signal and tune the Q-Multiplier to remove the interference.

Keep in mind that the Q-BALANCE control is a balancing device when the 2-BQ is used for notching and as such it has only one correct setting. Even a very slight movement of this control from its correct setting will result in a drastic reduction in attenuation.

Peaking a CW Signal

1. With the 2-BQ switches set for OFF and NOTCH, tune in a CW signal on the 2-B Receiver as described in the instruction book.
2. Now set the 2-BQ switches to ON and PEAK and tune the TUNING control to the signal by noting a marked increase in the S-meter reading.
3. Set the Q-BALANCE control for the desired sharpness of response. Adjusting the Q-BALANCE control clockwise to a point just short of where the unit breaks into oscillation will result in maximum selectivity for peaking purposes.

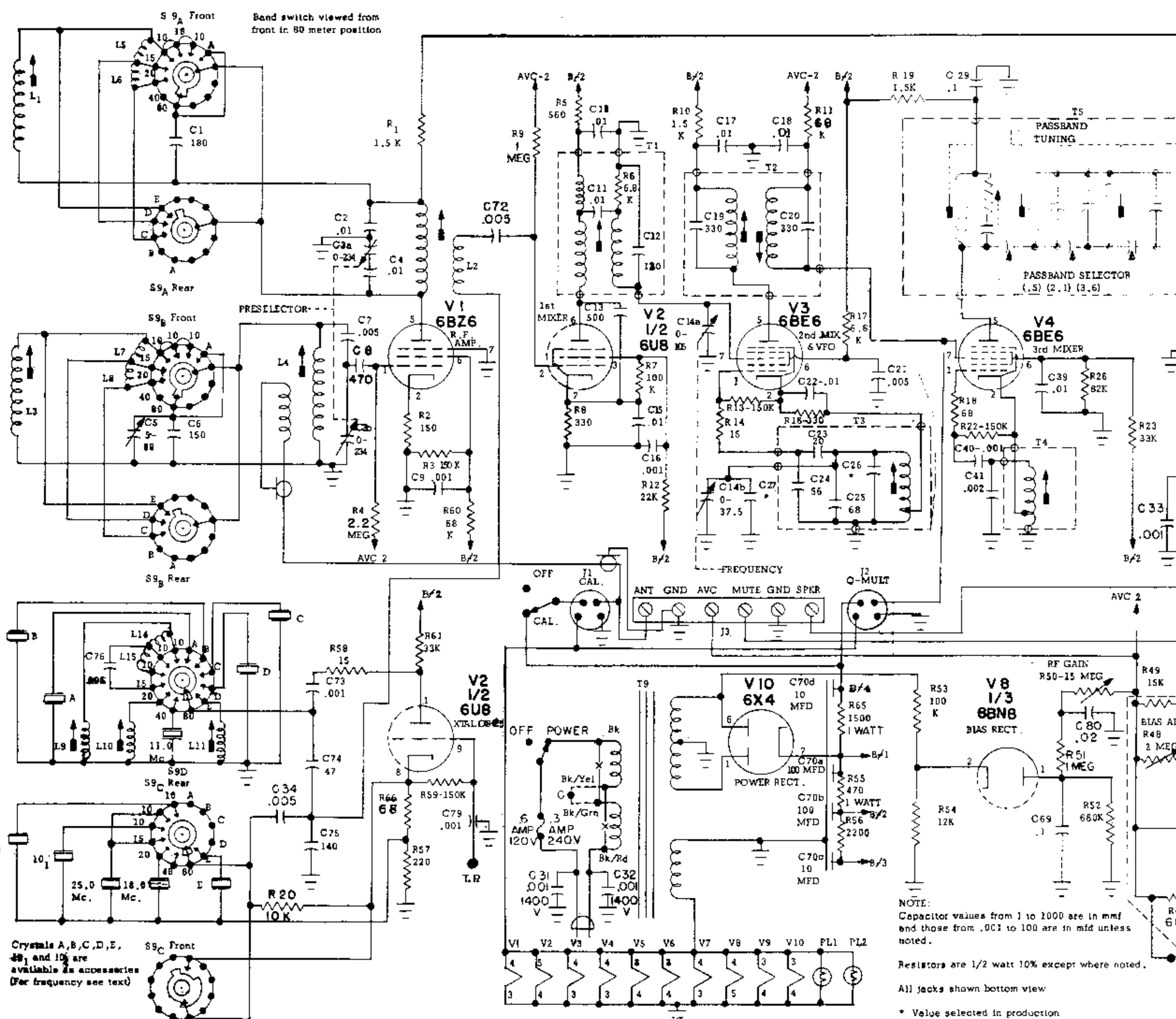

Crystals A, B, C, D, E, 481, and 10 are available as accessories (For frequency see text)

NOTE: Capacitor values from 1 to 1000 are in mmf and those from .001 to 100 are in mfd unless noted.

Resistors are 1/2 watt 10% except where noted.

All jacks shown bottom view

* Value selected in production

Highest Capacitor C80 Highest Resistor R71

For 240 volt operation, disconnect wires marked X and connect . . . An extra terminal on strip is provided for connection C.

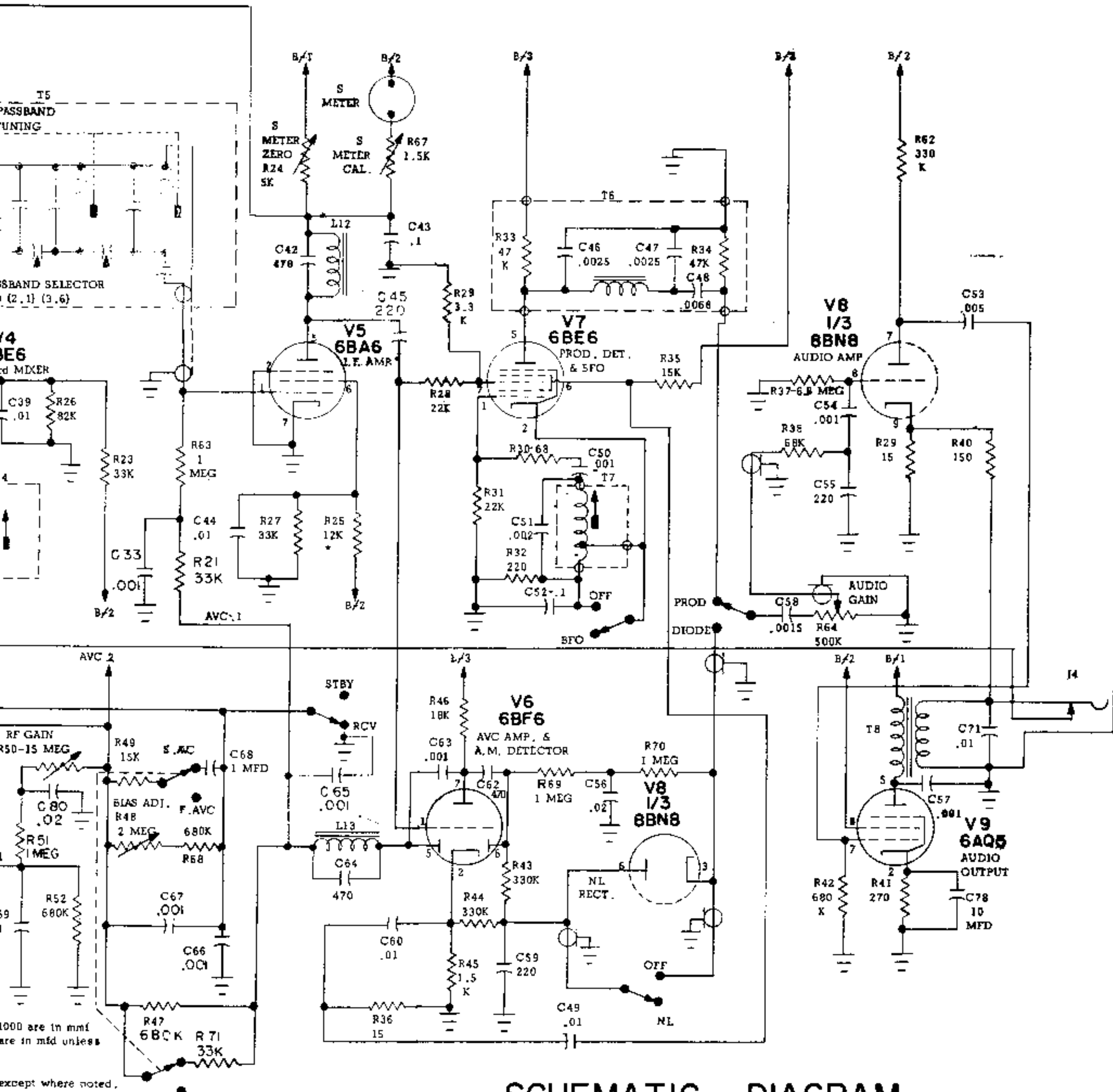

SCHEMATIC DIAGRAM MODEL 2-B COMMUNICATIONS RECEIVER

531626290

Alignment of the 2-C requires correct relationship between the various oscillators and should be done by competent service personnel with the necessary frequency determining equipment.

A. 50 KHz OSCILLATOR (BFO)

Connect an accurate source of 50 KHz signal through a capacitor to Pin 1 of V-5. With the MODE switch in either LSB or USB adjust the slug in T11 for zero beat. If a 2-AC crystal calibrator accessory is available, the BFO may be tuned by connecting Pin 1 of V-5 to the antenna terminal through a .01 mfd coupling capacitor.

If a frequency meter or receiver is being used rather than a generator, it should be loosely coupled to the output terminals (1 or 2) of T11 and tuned to the lowest 100 KHz point to which it can be set accurately. With the MODE switch in either LSB or USB adjust the slug in T11 for zero beat of its harmonic on the indicating instrument. A re-check should be made at the next higher 100 KHz point on the instrument to be sure the correct harmonic was reached.

B. 405/505 KHz OSCILLATOR

If a frequency meter or receiver is used, loosely couple to Pin 5 of V4. Switch the MODE switch to USB. Set the instrument to 1010 KHz and adjust the slug of T7 for zero beat. (Second harmonic of 505 KHz oscillator) Switch the MODE switch to LSB. Set the instrument to 810 KHz and adjust the trimmer capacitor C-54 for a zero beat.

If a signal generator is being used, feed a 455 KHz signal to Pin 7 of V4. This point is available through the 2-CQ socket J-2. Tune the slug of T7 for zero beat with the MODE switch in USB. Switch the MODE switch to LSB and adjust the trimmer capacitor C-54 for zero beat.

C. 455 KHz I.F.

Tune in a signal from the antenna and tune both top and bottom slugs of T4 for maximum S-meter reading or maximum negative voltage measured with a VTVM on IP-1.