

# DJ-195

# Service Manual

[www.r6-ru4montesechieta.it](http://www.r6-ru4montesechieta.it)

IZ5CCV

## CONTENTS

### SPECIFICATIONS

- 1) GENERAL ..... 2
- 2) TRANSMITTER ..... 2
- 3) RECEIVER ..... 2

### CIRCUIT DESCRIPTION

- 1) Receiver System ..... 3, 4
- 2) Transmitter System ..... 4
- 3) PLL Synthesizer Circuit ..... 4, 5
- 4) CPU and Peripheral Circuits ..... 5, 6
- 5) M3826M8L\*\*\*GP (XA0644) ..... 6~8

### SEMICONDUCTOR DATA

- 1) NMJ2070MT1 (XA210) ..... 9
- 2) AT24C16N-10SI-2.7TER (XA0368) ..... 9
- 3) M5222FP-600C (XA0385) ..... 10
- 4) TK14521MTL (XA0515) ..... 11
- 5) M64082AGP (XA0543) ..... 12
- 6) NJM2904V-TE1 (XA0573) ..... 12
- 7) NJM2902V-TE1 (XA0596) ..... 12
- 8) S-81250SG-QD-T1 (XA0619) ..... 13
- 9) S-80845ALMP-EA9-T2 (XA0620) ..... 13
- 10) Transistor, Diode, and LED Outline Drawings ..... 14
- 11) LCD Connection (EL0044) ..... 14

### EXPLODED VIEW

- 1) Front View ..... 15
- 2) Rear View ..... 16

### PARTS LIST

- MAIN Unit ..... 17~19
- Mechanical Parts ..... 20
- Packing Parts ..... 20

### ADJUSTMENT

- 1) Required Test Equipment ..... 21, 22
- 2) Adjustment Mode ..... 23~26

### PC BOARD VIEW

- MAIN Unit ..... 27

### SCHEMATIC DIAGRAM ..... 28

### BLOCK DIAGRAM ..... 29

**ALINCO, INC.**



# SPECIFICATIONS

## 1) GENERAL

Frequency coverage	T : TX 144 ~ 147.995MHz RX 135 ~ 173.995MHz E : TX 144 ~ 145.995MHz RX 144 ~ 145.995MHz EAH : TX 135 ~ 173.995MHz RX 135 ~ 135.995MHz TFH : TX 150 ~ 173.995MHz RX 135 ~ 173.995MHz TLH : TX 150 ~ 173.995MHz RX 135 ~ 173.995MHz
Mode	F3E (FM)
Channel steps	5,10,12.5,15,20,25, & 30kHz
Memory channels	40 channels+1 CALL channel
Antenna connector	BNC (50Ω unbalanced)
Frequency stability	±5 ppm
Microphone input impedance	2kΩ nominal
Power supply requirement	6.0 ~ 16.0V DC (negative ground)
Current drain (at 13.8 V DC)	1.2A (typical) Transmit high at 5W 200mA (typical) Receive at 280mW 50mA (typical) standby 20mA (typical) Battery save on
Usable temperature range	-10 ~ +60°C (14 ~ 140°F)
Dimensions (Projections not included)	56 (W) × 124 (H) × 40 (D) mm (with EBP-48N) 2.2"(W) × 4.88"(H) × 1.57"(D) inches (with EBP-48N)
Weight	Approx. 375g (13.2oz) (with EBP-48N)
DTMF	16 Buttons Keypad
Sub audible Tone(CTCSS)	encoder/decoder installed (39tones)
Sub audible Tone (DCS)	encoder/decoder installed (104codes)

## 2) TRANSMITTER

Output power	Approx. 5W EBP-48N installed Approx. 5W 13.8V DC Approx. 0.8W (LOW)
Modulation system	Variable reactance frequency modulation
Spurious emissions	Less than -60dB
Max. frequency deviation	±5kHz

## 3) RECEIVER

Receive system	Double conversion superheterodyne
Intermediate frequencies	1st 21.7MHz / 2nd 450kHz
Sensitivity(12dB SINAD)	Less than -14.0μdB (0.2uV) [144 ~ 147.995MHz] Less than -12.0μdB (0.25uV) [135 ~ 173.995MHz]
Selectivity	-6dB : 12kHz or more -60dB : 26kHz or less
Audio output power	280mW (typical with an 8Ω load) 200mW (8Ω 10% THD)

# CIRCUIT DESCRIPTION

## 1) Receiver System

The receiver system is a double superheterodyne system with a 21.7MHz first IF and a 450kHz second IF.

### 1. Front End

The received signal at any frequency in the 130.00- to 173.995-MHz range is passed through the low-pass filter (L2, L3, L11, C13, C14, C15 and C60) and tuning circuit (L16 and D15), and amplified by the RF amplifier (Q11). The signal from Q11 is then passed through the tuning circuit (L17, L18, L19 and varicaps D13, D14 and D16) and converted into 21.7MHz by the mixer (Q9). The tuning circuit, which consists of L16, L17, varicaps D15 and D13, L18, L19, varicaps D14 and D16, is controlled by the tracking voltage from the CPU so that it is optimized for the reception frequency. The local signal from the VCO is passed through the buffer (Q13), and supplied to the source of the mixer (Q9). The radio uses the lower side of the superheterodyne system.

### 2. IF Circuit

The mixer mixes the received signal with the local signal to obtain the sum and difference between them. The crystal filter (XF1, XF2) selects 21.7MHz frequency from the results and eliminates the signals of the unwanted frequencies. The first IF amplifier (Q10) then amplifies the signal of the selected frequency.

### 3. Demodulator Circuit

After the signal is amplified by the first IF amplifier (Q10), it is input to pin 16 of the demodulator IC (IC5). The second local signal of 21.25MHz (shared with PLL IC reference oscillation), which is oscillated by the internal oscillation circuit in IC1 and crystal (X1), is input through pin 1 of IC5. Then, these two signals are mixed by the internal mixer in IC5 and the result is converted into the second IF signal with a frequency of 450kHz. The second IF signal is output from pin 3 of IC5 to the ceramic filter (FL1), where the unwanted frequency band of that signal is eliminated, and the resulting signal is sent back to the IC5 through pins 5.

The second IF signal input via pin 5 is demodulated by the internal limiter amplifier and quadrature detection circuit in IC5, and output as an audio signal through pin 10.

### 4. Audio Circuit

The audio signal from pin 10 of IC5 is compensated to the audio frequency characteristics in the de-emphasis circuit (R104, R103, C122, C121) and amplified by the AF amplifier (Q26). The signal is then input to pin 2 of the electronic volume (IC4) for volume adjustment, and output from pin 1. The adjusted signal is sent to the audio power amplifier (IC3) through pin 2 to drive the speaker.

## 5. Squelch Circuit

The signal except for the noise component in AF signal of IC5 is cut by the active filter inside IC. The noise component is amplified and rectified, then converted to the DC voltage to output from pin13 of IC5. The voltage is led to pin 2 of CPU and compared with the setting voltage. The squelch will open if the input voltage is lower than the setting voltage.

## 2) Transmitter System

### 1. Modulator Circuit

The audio signal is converted to an electric signal in either the internal or external microphone, and input to the microphone amplifier (IC7). IC7 consists of two operational amplifiers; one amplifier (pins 5, 6, and 7) is composed of pre-emphasis and IDC circuits and the other (pins 1, 2, and 3) is composed of a splatter filter. The maximum frequency deviation is obtained by VR202 and input to the cathode of the varicap of the VCO, to change the electric capacity in the oscillation circuit. This produces the frequency modulation.

### 2. Power Amplifier Circuit

The transmitted signal is oscillated by the VCO, amplified by the pre-drive amplifier (Q4) and drive amplifier (Q3), and input to the final amplifier (Q2). The signal is then amplified by the final amplifier (Q2) and led to the antenna switch (D1) and low-pass filter (L5, L4, L3, L2, C16, C15, C14 and C13), where unwanted high harmonic waves are reduced as needed, and the resulting signal is supplied to the antenna.

### 3. APC Circuit

Part of the transmission power from the low-pass filter is detected by D6, converted to DC, and then amplified by a differential amplifier. The output voltage controls the bias voltage from the source of Q2 and Q3 to maintain the transmission power constant.

## 3) PLL Synthesizer Circuit

### 1. PLL

The dividing ratio is obtained by sending data from the CPU (IC9) to pin 2 and sending clock pulses to pin 3 of the PLL IC (IC1). The oscillated signal from the VCO is amplified by the buffer (Q5) and input to pin 6 of IC1. Each programmable divider in IC1 divides the frequency of the input signal by N according to the frequency data, to generate a comparison frequency of 5 or 6.25kHz.

### 2. Reference Frequency Circuit

The reference frequency appropriate for the channel steps is obtained by dividing the 21.25MHz reference oscillation (X1) by 4250 or 3400, according to the data from the CPU (IC9). When the resulting frequency is 5kHz, channel steps of 5, 10, 15, 20, 25, 30, and 50kHz are used. When it is 6.25kHz, the 12.5kHz channel step is used.

### 3. Phase Comparator Circuit

The PLL (IC1) uses the reference frequency, 5 or 6.25kHz. The phase comparator in the IC1 compares the phase of the frequency from the VCO with that of the comparison frequency, 5 or 6.25kHz, which is obtained by the internal divider in IC1.

### 4. PLL Loop Filter Circuit

If a phase difference is found in the phase comparison between the reference frequency and VCO output frequency, the charge pump output (pin 8) of IC1 generates a pulse signal, which is converted to DC voltage by the PLL loop filter and input to the varicap of the VCO unit for oscillation frequency control.

### 5. VCO Circuit

A Colpitts oscillation circuit driven by Q1 directly oscillates the desired frequency. The frequency control voltage determined in the CPU (IC9) and PLL circuit is input to the varicaps (D32 and D34). This change the oscillation frequency, which is amplified by the VCO buffer (Q5) and output from the VCO unit.

## 4) CPU and Peripheral Circuits

### 1. LCD Display Circuit

The CPU turns ON the LCD via segment and common terminals with 1/4 the duty and 1/3 the bias, at the frame frequency is 112.5Hz.

### 2. Display Lamp Circuit

When the LAMP key is pressed, "H" is output from pin 50 of CPU (IC9) to the bases of Q12. Q12 then turn ON and the LEDs (D12 and D17) light.

### 3. Reset and Backup

When the power from the DC jack or external battery increases from Circuits 0 V to 2.5 or more, "H" level reset signal is output from the reset IC (IC11) to pin 33 of the CPU (IC9), causing the CPU to reset. The reset signal, however, waits at 100, and does not enter the CPU until the CPU clock (X2) has stabilized.

### 4. S(Signal) Meter Circuit

The DC potential of pin 8 of IC5 is input to pin 1 of the CPU (IC9), converted from an analog to a digital signal, and displayed as the S-meter signal on the LCD.

### 5. DTMF Encoder

The CPU (IC9) is equipped with an internal DTMF encoder. The DTMF signal is output from pin 10, through R102 and R158 (for level adjustment), and then through the microphone amplifier (IC7), and is sent to the varicap of the VCO for modulation. At the same time, the monitoring tone passes through the AF circuit and is output from the speaker.6. CTCSS Encoder The CPU (IC9) is equipped with an internal tone encoder. The tone signal (67.0 to 250.3 Hz) is output from pin 9 of the CPU to the varicap (D3) of the VCO for modulation.

## 6. Tone Encoder

The CPU (IC9) is equipped with an internal tone encoder. The tone signal (67.0 to 250.3Hz) is output from pin 9 of the CPU to the varicap (D3) of the VCO for modulation.

## 7. DCS Encoder

The CPU (IC9) is equipped with an internal DCS code encoder. The code (023 to 754) is output from pin 9 of the CPU to the varicap (D3) of the PLL reference oscillator. When DCS is ON, DCS MUTE circuit (Q15-ON, Q18-ON, Q16-OFF) works. The modulation activates in X1 side only.

## 8. CTCSS, DCS Decoder

The voice band of the AF output signal from pin 10 of IC5 is cut by sharp active filter IC8 (VCVS) and amplified, then led to pin 4 of CPU. The input signal is compared with the programmed tone frequency code in the CPU. The squelch will open when they match.

## 9. Clock Shift

In the unlikely event that CPU clock noise is present on a particular operating frequency programmed into the radio, you can shift the CPU clock frequency to avoid the CPU clock-noise. The output signal from pin 31 of the CPU turns on Q30. Then the oscillation frequency of X2 will be shifted about 300 ppm.

## 5) M3826M8L\*\*\*GP (XA0644)

CPU

Terminal Connection  
(TOP VIEW)

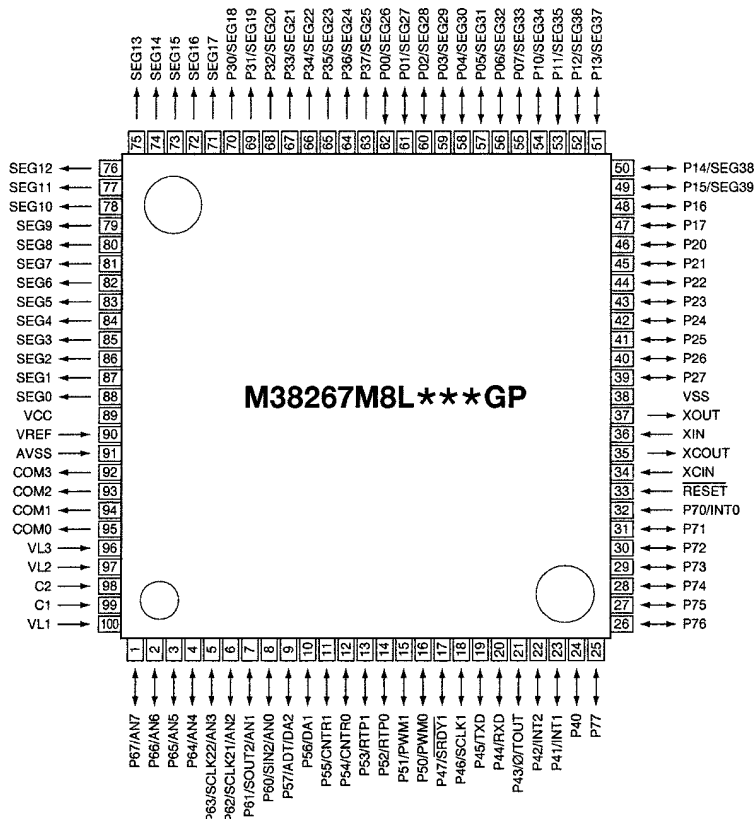

No.	Pin Name	Function	I/O	PU	Logic	Description
1	P67/AN7	SMT	I	-	A/D	S-meter input
2	P66/AN6	SQL	I	-	A/D	Noise level input for squelch
3	P65/AN5	BAT	I	-	A/D	Low battery detection input
4	P64/AN4	TIN	I	-	A/D	CTCSS tone input/DSC code input
5	P63/SCLK22/AN3	BP1	I	-	A/D	Band plan 1
6	P62/SCLK21/AN2	BP2	I	-	A/D	Band plan 2
7	P61/SOUT2/AN1	DCSW	O	-	Activ high	DCS signal mute
8	P60/SIN2/AN0	F/M/KEY	I	-	A/D	Function/Moniter key input
9	P57/ADT/DA2	CTOUT	O	-	D/A	CTCSS tone output/DCS tone output/Tuning voltage out
10	P56/DA1	DTOUT	O	-	D/A	DTMF output/EVR control output
11	P55/CNTR1	SCL	O	-	Pulse	Serial clock for EEPROM
12	P54/CNTR0	TBST	I/O	*	Pulse/Activ low	Tone burst output/UP input while trunking
13	P53/RTP1	BP4	I	-	-	Band plan 4
14	P52/RTP0	MUTE	I/O	-	Activ high	Microphone mute/Bank change input while trunking
15	P51/PWM3	CLK	O	-	Pulse	Serial clock output for PLL,CTCSS,and trunking board
16	P50/PWM0	DATA	I/O	-	Pulse	Serial data output for PLL,CTCSS,and trunking board/PLL unlock signal input
17	P47/SROY1	STBT	I/O	-	Activ low/Pulse	Trunking board detedtion(when PSW is on)/Storobe signal to trunking board
18	P46/SCLK1	STBP	O	-	Pulse	Strobe for PLL IC
19	P45/TXD	UTX	O	-	Pulse	UART data transmission output
20	P44/RXD	RTX	I	-	Pulse	UART data reception output
21	P43/ $\phi$ /TOUT	BEEP	I/O	-	Pulse/Activ low	Beep tone/Band plan 3(when PSW is on)
22	P42/INT2	RE2	I	*	Avtiv low	Rotary encoder input
23	P41/INT1	RE1	I	*	Avtiv low	
24	P40	SD	O	-	Avtiv low	Signal detection output
25	P77	PTT	I	-	Activ high	PTT input
26	P76	SDT	I	*	Activ high	Trunking signal detection input
27	P75	P5C	O	-	Activ low	PLL power ON/OFF output
28	P74	T5C	O	-	Activ low	TX power ON/OFF output
29	P73	R5C	O	-	Activ low	RX power ON/OFF output
30	P72	AFP	O	-	Activ low	AF AMP power ON/OFF output
31	P71	CLSFT	O	-	Activ high	CLOCK frequency shift
32	P70/INTO	BU	I	-	Activ low	Backup signal detection input
33	RESET	RESET	I	-	Activ low	Reset input
34	Xcin	Xcin	-	-	-	-
35	Xcout	Xcout	-	-	-	-
36	Xin	Xin	-	-	-	Main clock input
37	Xout	Xout	-	-	-	Main clock output
38	Vss	GND	-	-	-	CPU GND
39	P27	PSW	I	-	Avtiv low	Power switch input
40	P26	SDA	O	-	Pulse	Serial data for EEPROM
41	P25	C5C	O	-	Activ high	C5V power ON/OFF output
42	P24	LAMP	O	-	Activ high	Lamp ON/OFF
43	P23	KI0	I	*	Avtiv low	Key matrix input
44	P22	KI1	I	*	Avtiv low	
45	P21	KI2	I	*	Avtiv low	
46	P20	KI3	I	*	Avtiv low	
47	P17	KO3	O	-	Avtiv low	Key matrix output
48	P16	KO2	O	-	Avtiv low	
49	P15/SEG39	KO1	O	-	Avtiv low	
50	P14/SEG38	KO0	O	-	Avtiv low	
51	P13/SEG37	H/L	O	-	-	Tx power H/L
52	P12/SEG36	DA2	O	-	-	DA converter for output power
53	P11/SEG35	DA1	O	-	-	DA converter for output power
54	P10/SEG34	DA0	O	-	-	DA converter for output power
55	P07/SEG33	SCR	I	*	-	SCR input

No.	Pin Name	Function	I/O	PU	Logic	Description
56	P06/SEG32	AFC	O	-	Activ high	AF tone control
57	P05/SEG31	S31	O	-	-	LCD segment signal
58	P04/SEG30	S30	O	-	-	
59	P03/SEG29	S29	O	-	-	
60	P02/SEG28	S28	O	-	-	
61	P01/SEG27	S27	O	-	-	
62	P00/SEG26	S26	O	-	-	
63	P37/SEG25	S25	O	-	-	
64	P36/SEG24	S24	O	-	-	
65	P35/SEG23	S23	O	-	-	
66	P34/SEG22	S22	O	-	-	
67	P33/SEG21	S21	O	-	-	
68	P32/SEG20	S20	O	-	-	
69	P31/SEG19	S19	O	-	-	
70	P30/SEG18	S18	O	-	-	
71	SEG17	S17	O	-	-	
72	SEG16	S16	O	-	-	
73	SEG15	S15	O	-	-	
74	SEG14	S14	O	-	-	
75	SEG13	S13	O	-	-	
76	SEG12	S12	O	-	-	
77	SEG11	S11	O	-	-	
78	SEG10	S10	O	-	-	
79	SEG9	S9	O	-	-	
80	SEG8	S8	O	-	-	
81	SEG7	S7	O	-	-	
82	SEG6	S6	O	-	-	
83	SEG5	S5	O	-	-	
84	SEG4	S4	O	-	-	
85	SEG3	S3	O	-	-	
86	SEG2	S2	O	-	-	
87	SEG1	S1	O	-	-	
88	SEG0	S0	O	-	-	
89	Vcc	VDD	-	-	-	CPU power terminal
90	Vref	Vref	-	-	-	AD converter power supply
91	Avss	Avss	-	-	-	AD converter GND
92	COM3	COM3	O	-	-	LCD COM3 output
93	COM2	COM2	O	-	-	LCD COM2 output
94	COM1	COM1	O	-	-	LCD COM1 output
95	COM0	COM0	O	-	-	LCD COM0 output
96	VL3	VL3	-	-	-	LCD power supply
97	VL2	VL2	-	-	-	
98	C2	I	-	-	-	-
99	C1	C1	-	-	-	-
100	VL1	VL1	I	-	A/D	LCD power supply

# SEMICONDUCTOR DATA

## 1) NMJ2070MT1 (XA210)

Low Voltage Power Amplifier

Equivalent Circuit

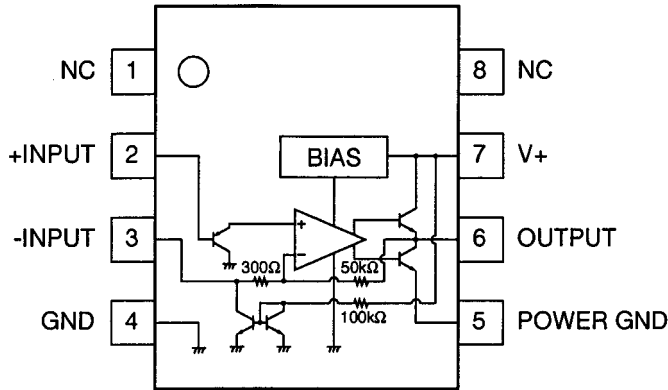

$V_+ = 6V, T_a = 25 \pm 2^\circ C$

Parameter	Condition	Symbol	Min.	Typ.	Max.	Unit	
Supply voltage		$V_+$	1.8	-	15	V	
Idle current	$R_L =$	$I_Q$	-	4	7	mA	
Output voltage		$V_o$	-	2.7	-	V	
Input bias current		$I_B$	-	200	-	nA	
Output power	THD=10%, $f=1kHz$	$P_o$	$V_+ = 6V, R_L = 4$	0.5	0.6	-	W
			$V_+ = 4.5V, R_L = 4$	-	0.32	-	W
			$V_+ = 3V, R_L = 4$	-	120	-	mW
			$V_+ = 2V, R_L = 4$	-	30	-	mW
	THD=10%, $f=1kHz$		$V_+ = 6V, R_L = 4$	-	500	-	mW
			$V_+ = 4.5V, R_L = 4$	-	250	-	mW
Distortion	$P_o = 0.4W, R_L = 4, f = 1kHz$	THD	-	0.25	-	%	
Voltage gain	$f = 1kHz$	$A_v$	41	44	47	dB	
Input impedance	$f = 1kHz$	$Z_{IN}$	100	-	-	k	
Equivalent input noise voltage	$R_s = 10k$	A curve	$V_{n1}$	-	2.5	-	$\mu V$
		B=22Hz to 22kHz	$V_{n2}$	-	3	-	$\mu V$
Power supply voltage rejection ratio	$f = 100Hz, C_x = 100\mu F$	SVR	24	30	-	dB	
Power gain band width (-3dB)	$R_L = 8, P_o = 250mW$	P.B	-	200	-	kHz	

## 2) AT24C16N-10SI-2.7TER (XA0368)

16K bits CMOS Serial EEPROM

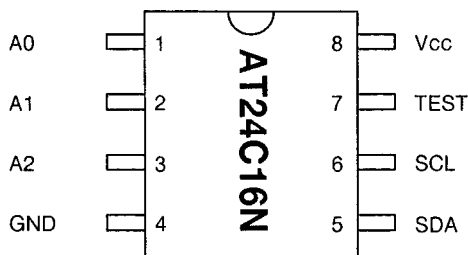

Pin Name	Function
A0 to A2	Address inputs
SDA	Serial Data
SCL	Serial Clock
Test	Test Input (GND or Vcc)
NC	No connection

### 3) M5222FP-600C (XA0385)

#### Electronic Volume

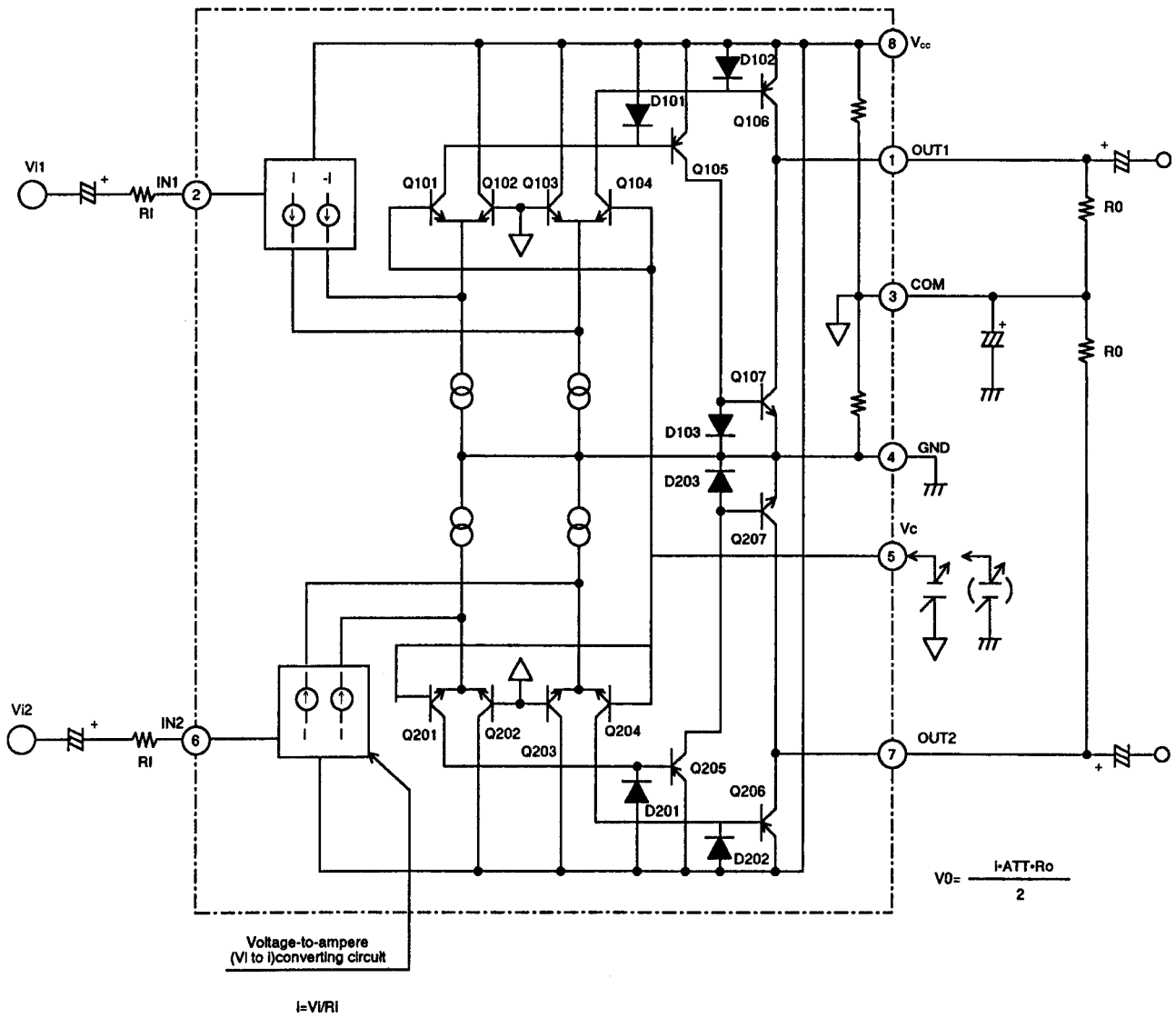

#### 4) TK14521MTL (XA0515)

##### IF System

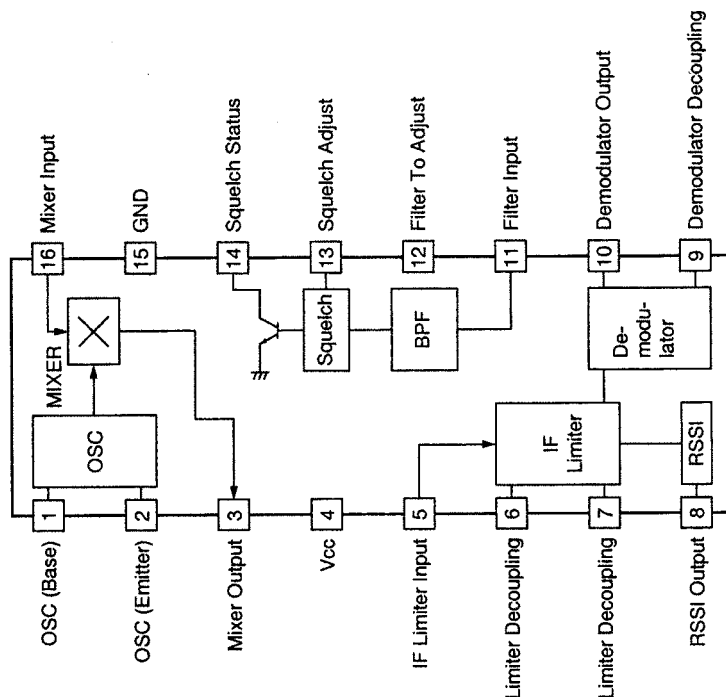

Ta = 25°C, Vcc = 3V, fin = 10.7MHz, fm = 1kHz, Mod = ±3kHz

Parameter	Symbol	Ratings			Unit	Condition
		Min	Typical	Max		
Supply Current	I <sub>cc</sub>	4.3	7.0	9.8	mA	No signal
<b>Mixer + IF part</b>						
Limiting Sensitivity	Limit	-94	-100	-106	dBm	-3.0dB point
Output Voltage	V <sub>o</sub>	200	300	400	mV <sub>rms</sub>	
Distortion	THD		0.8	2.8	%	
S/N	S/N	40	46	52	dB	
AM Rejection Ratio	AMRR	30	40		dB	AM 30% mod
Mixer Conversion Gain	G <sub>M</sub>	20	26	32	dB	
Mixer 3rd Intercept point	ICP	-10	-3		dBm	
Mixer Input Impedance	R <sub>IM</sub>	2.8	3.6	4.4	KΩ	DC Test
Mixer Output Impedance	R <sub>OM</sub>	1.2	1.5	1.9	KΩ	DC Test
Limiter Input Impedance	R <sub>IFIN</sub>	1.2	1.5	1.9	KΩ	DC Test
<b>RSSI part</b>						
RSSI Output Current 1	I <sub>RSSI 1</sub>	41	60	88	μA	-30dBm is input.
RSSI Output Current 2	I <sub>RSSI 2</sub>	22	40	59	μA	-60dBm is input.
RSSI Output Current 3	I <sub>RSSI 3</sub>	10	17	25	μA	-100dBm is input.
<b>Squelch BPF part</b>						
Center Frequency 1	f <sub>CT 1</sub>	10.5	15.0	21.0	kHz	Center frequency setting R=∞
Center Frequency 2	f <sub>CT 2</sub>	21.0	30.0	39.0	kHz	Center frequency setting R=36kΩ
Center Frequency 3	f <sub>CT 3</sub>	38.5	55.0	71.5	kHz	Center frequency setting R=6.8kΩ
Squelch Output Current	I <sub>SQ</sub>	6	10	18	μA	Center frequency setting R=36kΩ 25mV <sub>rms</sub> is input (Pin11)
Squelch ON Voltage	V <sub>SQ(ON)</sub>	0.40	0.47	0.54	V	DC voltage is input to pin13.
Squelch OFF Voltage	V <sub>SQ(OFF)</sub>	0.50	0.57	0.64	V	DC voltage is input to pin13.

**5) M64082AGP (XA0543)**

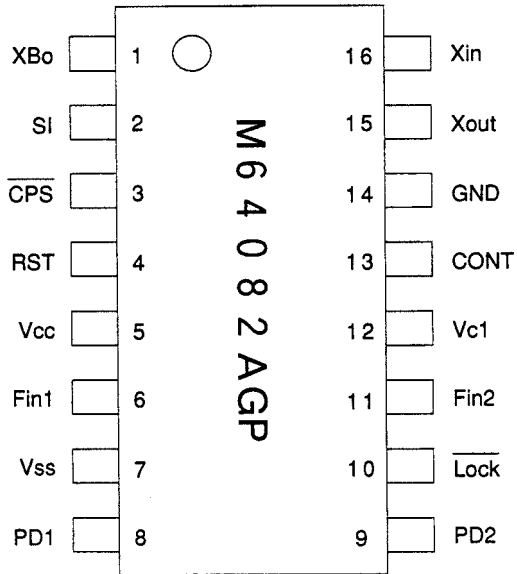

**6) NJM2904V-TE1 (XA0573)**

Dual Single Supply Operational Amplifier

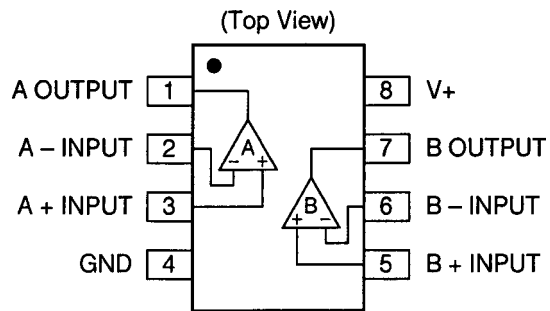
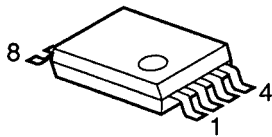

**7) NJM2902V-TE1 (XA0596)**

Quad Single Supply Operational Amplifier

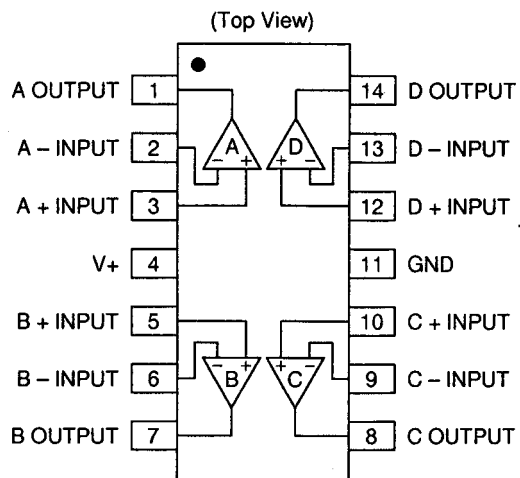
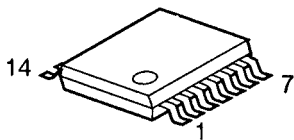

8) S-81250SG-QD-T1 (XA0619)

Top View

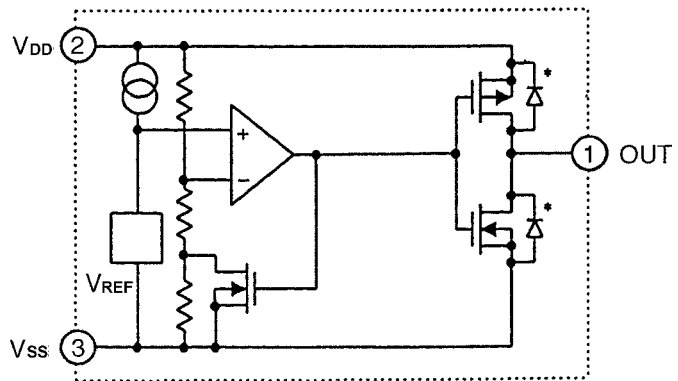
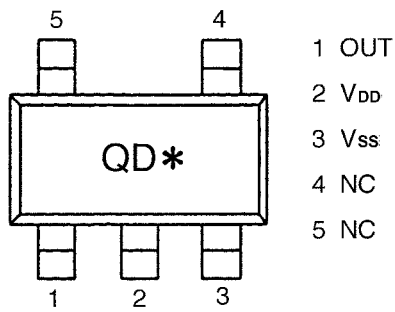

9) S-80845ALMP-EA9-T2 (XA0620)

Voltage Regulator

V<sub>in</sub>=18V

I<sub>out</sub>=100mA

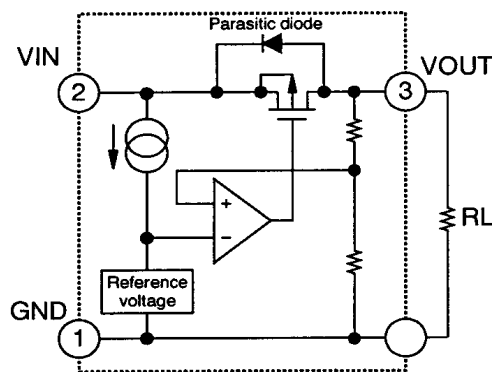
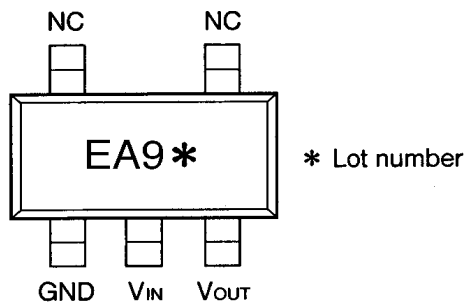

# 10) Transistor, Diode, and LED Outline Drawings

Top View

RSL135 TE11 XD0066	DA204U T106 XD0130	1SV214 TPH4 XD0131	MA741WA TX XD0251	MA741WK XD0252	S3DG7 XD0261	MA729-TX XD0291
U2FWJ44N (TE12R) XD0294	MA2S30400L XD0312	MA2S111-TX XD0323	HSU277TRF XD331	RB706F-40-T106 XD0332	MRF9745T1 XE0034	2SK2975-T11-A XE0038
2SK882-GR-TE85L XE0040	BRPG1201W TR XL0028	SML-310MTT86 XL0036	2SC4081 T106R XT0095	2SA1036K T146Q XT110	2SD2216R-TX XT0135	2SB766A-TX XT0170
2SC4808-TX-AR XT0171	2SC4618 XT0172	2SC2915 XT0178	UN9216-R-TX XU0099	RN2107 TE85L XU0192	RN1107 TE85L XU0193	RN2111 TE85L XU0194
XP1114 (TX) XU0161	XP1501-TX XU0172	RN1104 TE85L XU0195				
7Q	5R	XD				

# 11) LCD Connection (EL0044)

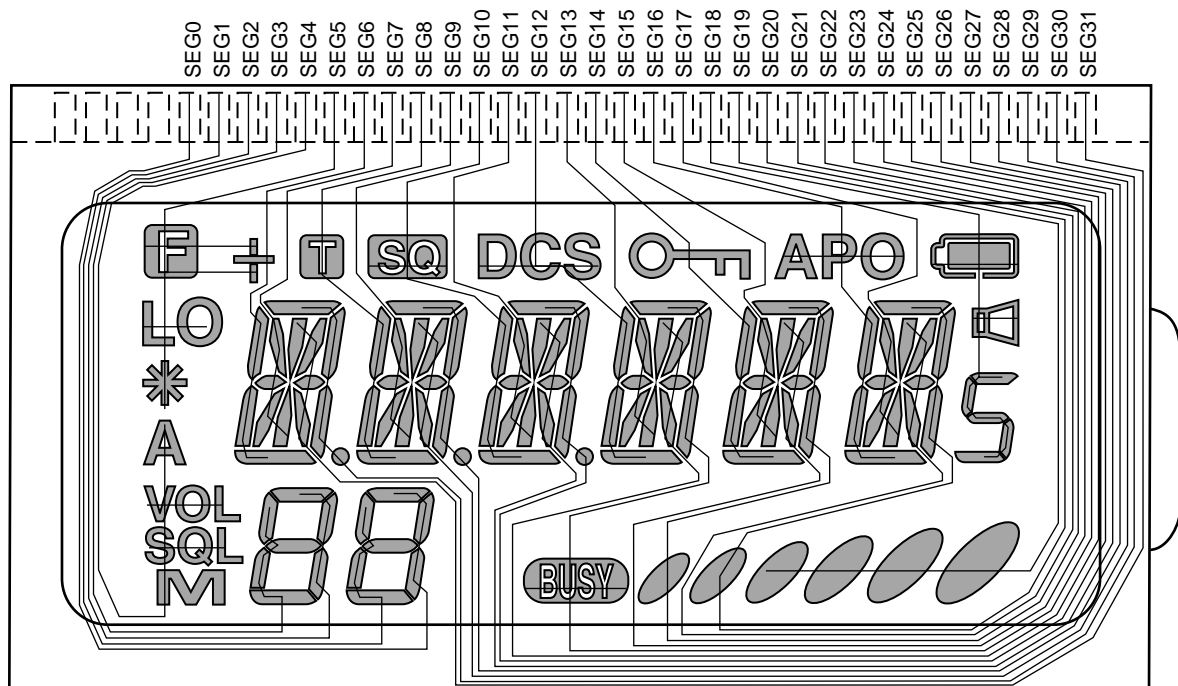



## 2) Rear View

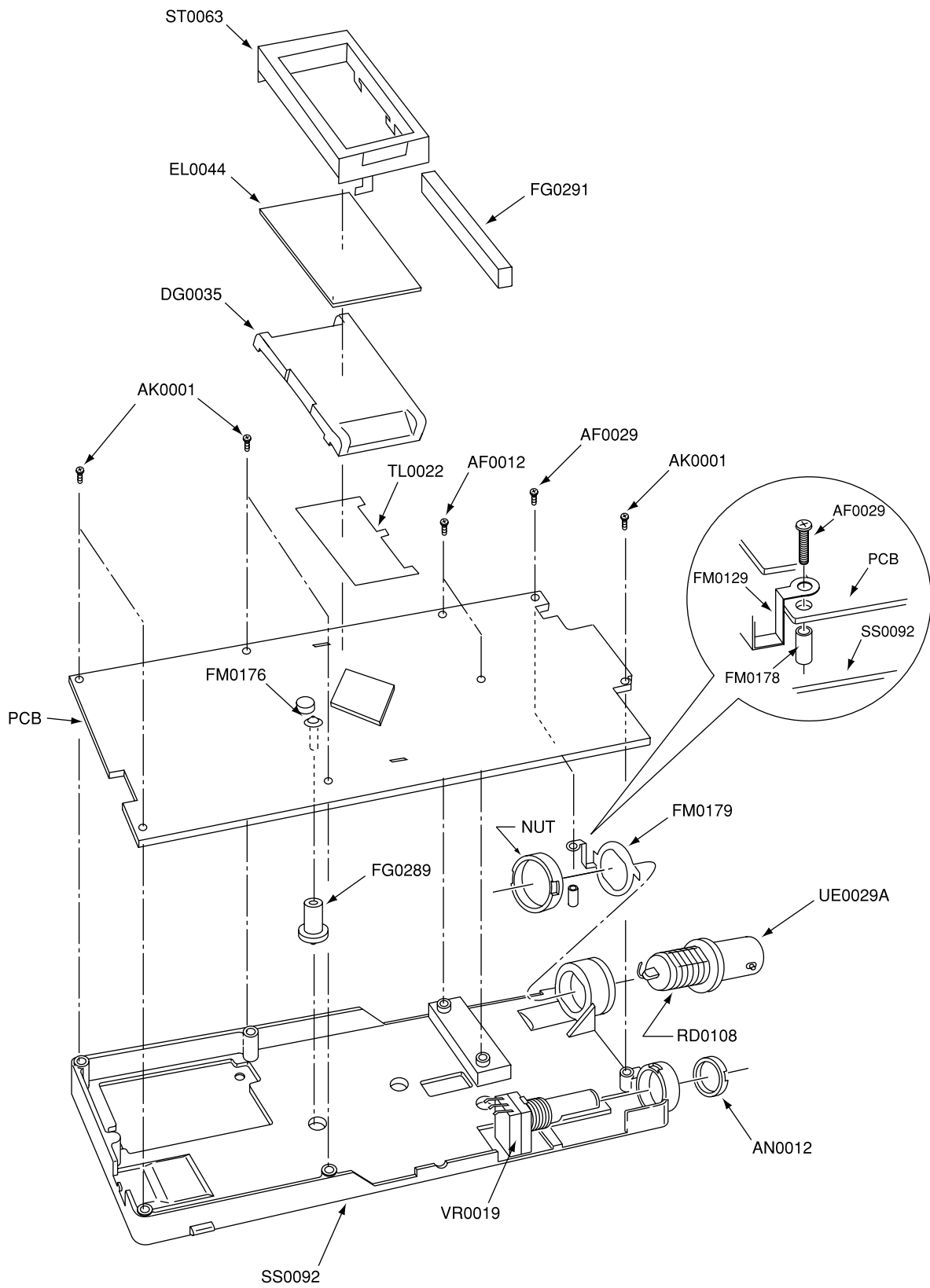

# PARTS LIST

Ref. No.	Parts No.	Description	Parts Name	Ver
Main Unit				
C1	CU3035	Chip C	C1608JB1H102KT-AS	
C2	CU3035	Chip C	C1608JB1H102KT-AS	
C3	CS0404	Chip Tantal	6MCM106MATER	
C4	CU3012	Chip C	C1608CH1H120JT-AS	
C5	CU3012	Chip C	C1608CH1H120JT-AS	
C6	CU3035	Chip C	C1608JB1H102KT-AS	
C7	CU3035	Chip C	C1608JB1H102KT-AS	
C8	CU3035	Chip C	C1608JB1H102KT-AS	
C9	CU3035	Chip C	C1608JB1H102KT-AS	
C10	CU3035	Chip C	C1608JB1H102KT-AS	
C11	CU3019	Chip C	C1608CH1H470JT-AS	
C12	CU3015	Chip C	C1608CH1H220JT-AS	
C13	CU3011	Chip C	C1608CH1H100DT-AS	
C14	CU3014	Chip C	C1608CH1H180JT-AS	
C15	CU3016	Chip C	C1608CH1H270JT-AS	
C16	CU3085	Chip C	C1608CH1H300JT-AS	
C17	CU3004	Chip C	C1608CH1H030CT-AS	
C18	CU3001	Chip C	C1608CH1HOR5CT-AS	
C19	CU3020	Chip C	C1608CH1H560JT-AS	
C20	CU3016	Chip C	C1608CH1H270JT-AS	
C21	CU3003	Chip C	C1608CH1H020CT-AS	
C22	CU3035	Chip C	C1608JB1H102KT-AS	
C23	CU3004	Chip C	C1608CH1H030CT-AS	
C24	CU3002	Chip C	C1608CH1H010CT-AS	
C25	CU3012	Chip C	C1608CH1H120JT-AS	
C26	CU3015	Chip C	C1608CH1H220JT-AS	
C27	CU3002	Chip C	C1608CH1H010CT-AS	
C28	CU3002	Chip C	C1608CH1H010CT-AS	
C29	CU3035	Chip C	C1608JB1H102KT-AS	
C30	CU0108	Chip C	LMK212BJ105KG	
C31	CU3047	Chip C	C1608JB1H103KT-N	
C32	CU3035	Chip C	C1608JB1H102KT-AS	
C33	CU3047	Chip C	C1608JB1H103KT-N	
C34	CU3035	Chip C	C1608JB1H102KT-AS	
C35	CU3035	Chip C	C1608JB1H102KT-AS	
C36	CU0108	Chip C	LMK212BJ105KG	
C37	CU3035	Chip C	C1608JB1H102KT-AS	
C38	CU3027	Chip C	C1608CH1H221JT-AS	
C39	CU3035	Chip C	C1608JB1H102KT-AS	
C40	CU3002	Chip C	C1608CH1H010CT-AS	
C41	CU3002	Chip C	C1608CH1H010CT-AS	
C42	NC			
C43	CU3035	Chip C	C1608JB1H102KT-AS	
C44	CU3035	Chip C	C1608JB1H102KT-AS	
C45	CU3035	Chip C	C1608JB1H102KT-AS	
C46	CU0108	Chip C	LMK212BJ105KG	
C47	CU3035	Chip C	C1608JB1H102KT-AS	
C48	CU3035	Chip C	C1608JB1H102KT-AS	
C49	CU3047	Chip C	C1608JB1H103KT-N	
C50	CU3035	Chip C	C1608JB1H102KT-AS	
C51	CU3047	Chip C	C1608JB1H103KT-N	
C52	CS0404	Chip Tantal	6MCM106MATER	
C53	CU3014	Chip C	C1608CH1H180JT-AS	
C54	CU3047	Chip C	C1608JB1H103KT-N	
C55	CU3035	Chip C	C1608JB1H102KT-AS	
C56	CU3002	Chip C	C1608CH1H010CT-AS	
C57	CU3002	Chip C	C1608CH1H010CT-AS	
C58	CU3015	Chip C	C1608CH1H220JT-AS	
C59	CU3007	Chip C	C1608CH1H060CT-A	
C61	CU3047	Chip C	C1608JB1H103KT-N	
C62	CU3111	Chip C	C1608JB1C104KT-N	
C63	CS0407	Chip Tantal	35MC104MATER	
C64	CU3011	Chip C	C1608CH1H100DT-AS	
C65	CU3011	Chip C	C1608CH1H100DT-AS	
C66	CU3035	Chip C	C1608JB1H102KT-AS	
C67	CU3012	Chip C	C1608CH1H120JT-AS	
C68	CU3047	Chip C	C1608JB1H103KT-N	
C69	CU3057	Chip C	C1608CH1H130JT-AS	
C70	CU3016	Chip C	C1608CH1H270JT-AS	
C71	CU3035	Chip C	C1608JB1H102KT-AS	
C72	CS0406	Chip Tantal	35MCM105MATER	
C73	CU3017	Chip C	C1608CH1H330JT-AS	T.E.EAH
C73	CU3085	Chip C	C1608CH1H300JT-AS	TFH.TLH
C74	CU3019	Chip C	C1608CH1H470JT-AS	
C75	CU3018	Chip C	C1608CH1H390JT-AS	
C76	CU3047	Chip C	C1608JB1H103KT-N	
C77	CU3003	Chip C	C1608CH1H020CT-AS	
C78	CU3011	Chip C	C1608CH1H100JT-AS	

Ref. No.	Parts No.	Description	Parts Name	Ver
C79	CU0108	Chip C	LMK212BJ105KG	
C80	CU3035	Chip C	C1608JB1H102KT-AS	
C81	CU3016	Chip C	C1608CH1H270JT-AS	
C82	CU3035	Chip C	C1608JB1H102KT-AS	
C83	CU3111	Chip C	C1608JB1C104KT-N	
C84	CU3035	Chip C	C1608JB1H102KT-AS	
C85	CU3016	Chip C	C1608CH1H270JT-AS	
C86	CU3035	Chip C	C1608JB1H102KT-AS	
C87	CE0392	Electrolytic C	6MV47UW	
C88	CU3035	Chip C	C1608JB1H102KT-AS	
C89	CS0405	Chip Tantal	10MCS475MATER	
C90	CU3035	Chip C	C1608JB1H102KT-AS	
C91	CU3035	Chip C	C1608JB1H102KT-AS	
C92	CU0108	Chip C	LMK212BJ105KG	
C93	CU3047	Chip C	C1608JB1H103KT-N	
C94	CS0404	Chip Tantal	6MCM106MATER	
C95	CU3035	Chip C	C1608JB1H102KT-AS	
C96	CS0408	Chip Tantal	6MCM156MATER	
C97	CU3035	Chip C	C1608JB1H102KT-AS	
C98	CU0108	Chip C	LMK212BJ105KG	
C99	CS0408	Chip Tantal	6MCM156MATER	
C100	CU3035	Chip C	C1608JB1H102KT-AS	
C101	CU3035	Chip C	C1608JB1H102KT-AS	
C102	CE0392	Electrolytic C	6MV47UW	
C103	CE0373	Electrolytic C	16MV 100UW	
C104	CU0108	Chip C	LMK212BJ105KG	
C105	CU3047	Chip C	C1608JB1H103KT-N	
C106	CU3035	Chip C	C1608JB1H102KT-AS	
C107	CS0404	Chip Tantal	6MCM106MATER	
C108	CS0404	Chip Tantal	6MCM106MATER	
C109	CU3047	Chip C	C1608JB1H103KT-N	
C110	CU3035	Chip C	C1608JB1H102KT-AS	
C111	CU3111	Chip C	C1608JB1C104KT-N	
C112	CU3111	Chip C	C1608JB1C104KT-N	
C113	CU3035	Chip C	C1608JB1H102KT-AS	
C114	CE0397	Electrolytic C	MVS16VC47MF46	
C115	CU3047	Chip C	C1608JB1H103KT-N	
C116	CU3051	Chip C	C1608JB1E223KT-NS	
C117	CU3051	Chip C	C1608JB1E223KT-NS	
C118	CU0108	Chip C	LMK212BJ105KG	
C119	CU3111	Chip C	C1608JB1C104KT-N	
C120	CE0396	Electrolytic C	MVS6.3VC100MF46	
C121	CU3051	Chip C	C1608JB1E223KT-NS	
C122	CU3111	Chip C	C1608JB1C104KT-N	
C123	CU3111	Chip C	C1608JB1C104KT-N	
C124	CS0404	Chip Tantal	6MCM106MATER	
C125	CU3035	Chip C	C1608JB1H102KT-AS	
C126	CU3111	Chip C	C1608JB1C104KT-N	
C127	CU3025	Chip C	C1608CH1H151JT-AS	
C128	CU3035	Chip C	C1608JB1H102KT-AS	
C129	CU3111	Chip C	C1608JB1C104KT-N	
C130	CU3041	Chip C	C1608JB1H332KT-NS	
C131	CU0108	Chip C	LMK212BJ105KG	
C132	CU3111	Chip C	C1608JB1C104KT-N	
C133	CU3047	Chip C	C1608JB1H103KT-N	
C134	CU3038	Chip C	C1608JB1H182KT-AS	
C135	CU3053	Chip C	C1608JF1E333ZT-N	
C136	CU3111	Chip C	C1608JB1C104KT-N	
C137	CU3035	Chip C	C1608JB1H102KT-AS	
C138	CU3111	Chip C	C1608JB1C104KT-N	
C139	CU3035	Chip C	C1608JB1H102KT-AS	
C140	CU3035	Chip C	C1608JB1H102KT-AS	
C141	CU3035	Chip C	C1608JB1H102KT-AS	
C142	CU0108	Chip C	LMK212BJ105KG	
C143	CU3051	Chip C	C1608JB1E223KT-NS	
C144	CU3047	Chip C	C1608JB1H103KT-N	
C145	CU3021	Chip C	C1608CH1H680JT-AS	
C146	CU3101	Chip C	C1608JB1C473KT-NS	
C147	CU3111	Chip C	C1608JB1C104KT-N	
C148	CU3111	Chip C	C1608JB1C104KT-N	
C149	CS0404	Chip Tantal	6MCM106MATER	
C150	CU3047	Chip C	C1608JB1H103KT-N	
C151	CU3047	Chip C	C1608JB1H103KT-N	
C152	CU0108	Chip C	LMK212BJ105KG	
C153	CU3047	Chip C	C1608JB1H103KT-N	
C154	CU0108	Chip C	LMK212BJ105KG	
C155	CS0405	Chip Tantal	10MCS475MATER	
C156	CU3014	Chip C	C1608CH1H180JT-AS	
C157	CU3013	Chip C	C1608CH1H150JT-AS	

Ref. No.	Parts No.	Description	Parts Name	Ver
C158	CU0108	Chip C	LMK212BJ105KG	
C159	CU3035	Chip C	C1608JB1H102KT-AS	
C160	CU3047	Chip C	C1608JB1H103KT-N	
C161	CS0404	Chip Tantal	6MCM106MATER	
C162	CU3111	Chip C	C1608JB1C104KT-N	
C163	CU3111	Chip C	C1608JB1C104KT-N	
C164	CU3046	Chip C	C1608JB1H822KT-NS	
C165	CU3111	Chip C	C1608JB1C104KT-N	
C166	CU3044	Chip C	C1608JB1H562KT-NS	
C167	CU3040	Chip C	C1608JB1H272KT-NS	
C168	CU3050	Chip C	C1608JB1E183KT-A	
C169	CU3035	Chip C	C1608JB1H102KT-AS	
C170	CU3035	Chip C	C1608JB1H102KT-AS	
C171	CU3035	Chip C	C1608JB1H102KT-AS	
C172	CU3101	Chip C	C1608JB1C473KT-NS	
C173	CU3035	Chip C	C1608JB1H102KT-AS	
C174	CU3101	Chip C	C1608JB1C473KT-NS	
C175	NC			
C176	NC			
C177	NC			
C178	NC			
C179	CU3049	Chip C	C1608JB1E153KT-NS	
CN1	UE0350	Connector	DF12D(3.5)20DP0.5V81	
D1	XD0066	Diode	RLS135 TE 11	
D2	XD0312	Diode	MA2S30400L	
D3	XD0131	Diode	1SV214 TPH4	
D4	XD0312	Diode	MA2S30400L	
D5	XD0331	Diode	HSU277TRF	
D6	XD0251	Diode	MA741WA TX	
D7	XD0323	Diode	MA2S111-TX	
D8	XD0261	Diode	S3DG7	
D9	XD0130	Diode	DA204U T106	
D10	XD0323	Diode	MA2S111-TX	
D11	XD0294	Diode	U2FWJ44N(TE12R)	
D12	XL0036	Chip LED	SML-310MTT86	
D13	XD0312	Diode	MA2S30400L	
D14	XD0312	Diode	MA2S30400L	
D15	XD0312	Diode	MA2S30400L	
D16	XD0312	Diode	MA2S30400L	
D17	XL0036	Chip LED	SML-310MTT86	
D18	XD0131	Diode	1SV214 TPH4	
D19	XL0028	Chip LED	BRPG1201W TR	
D20	XD0291	Diode	MA729-TX	
D21	XD0332	Diode	RB706F-40-T106	
D22	XD0323	Diode	MA2S111-TX	
D23	NC			
FL1	XC0060	Filter	ALFYM450F=K	
IC1	XA0543	IC	M64082AGP	
IC2	XA0619	IC	S-81250SG-QD-T1	
IC3	XA0210	IC	NJM2070M T1	
IC4	XA0385	IC	M5222FP-600C	
IC5	XA0515	IC	TK14521MTL	
IC7	XA0573	IC	NJM2904V-TE1	
IC8	XA0596	IC	NJM2902V-TE1	
IC9	XA0644	CPU	M38267E8L-GP	
IC10	XA0368	IC	AT24C16N-10SI-2.7TER	
IC11	XA0620	IC	S-80845ALMP-EA9-T2	
JK2	UJ0046	Jack	MJ82-1	
JK3	UJ0019	Jack	HSJ11493-01-010	
JK4	UJ0022	Jack	HSJ1102-01-540	
L1	QC0508	Coil	LK16082R2K-T	
L2	QKA45A	Coil	MR1.5 4.5T 0.4	
L3	QKA45A	Coil	MR1.5 4.5T 0.4	
L4	QKA65A	Coil	MR1.5 3.5T 0.4	
L5	QKA45A	Coil	MR1.5 4.5T 0.4	
L6	QC0571	Coil	LL1608-FH68NJ	
L7	QC0566	Coil	LL1608-FH27NJ	
L8	QC0570	Coil	LL1608-FH56NJ	
L9	QC0573	Coil	LL1608-FHR10J	
L10	QKA75A	Coil	QKA75A	
L11	QC0535	Coil	LQN21A56NJ04	
L12	QC0538	Coil	LQN21AR10J04	
L13	QC0570	Coil	LL1608-FH56NJ	
L15	QC0508	Coil	LK16082R2K-T	
L16	QC0537	Coil	LQN21A82NJ04	
L17	QC0537	Coil	LQN21A82NJ04	
L18	QC0537	Coil	LQN21A82NJ04	
L19	QC0537	Coil	LQN21A82NJ04	
L20	QC0573	Coil	LL1608-FHR10J	
L21	QC0089	Coil	NL322522T-181JA	
LCD1	EL0044	LCD	HT-3404	
MIC1	EY0017	Microphone	OB-27P44	
PCB	UP0376	PCB	DJ195 INTEGRATED	
Q1	XT0171	Transistor	2SC4808-TX.AR	

Ref. No.	Parts No.	Description	Parts Name	Ver
Q2	XE0038	FET	2SK2975-T11-A	
Q3	XE0034	FET	MRF9745T1	
Q4	XT0171	Transistor	2SC4808-TX.AR	
Q5	XT0171	Transistor	2SC4808-TX.AR	
Q6	XU0172	Transistor	XP1501-TX	
Q7	XT0135	Transistor	2SD2216R-TX	
Q8	XT0170	Transistor	2SB766A-TX	
Q9	XE0040	FET	2SK882-GR-TE85L	
Q10	XT0172	Transistor	2SC4618	
Q11	XE0040	FET	2SK882-GR-TE85L	
Q12	XU0193	Transistor	RN1107 TE85L	
Q13	XT0178	Transistor	2SC4915-O TE85L	
Q14	XT0170	Transistor	2SB766A-TX	
Q15	XU0193	Transistor	RN1107 TE85L	
Q16	XU0193	Transistor	RN1107 TE85L	
Q17	XT0170	Transistor	2SB766A-TX	
Q18	XU0193	Transistor	RN1107 TE85L	
Q19	XT0110	Transistor	2SA1036K T146Q	
Q20	XU0172	Transistor	XP1501-TX	
Q21	XU0172	Transistor	XP1501-TX	
Q22	XU0161	Transistor	XP1114(TX)	
Q23	XU0192	Transistor	RN2107 TE85L	
Q24	XT0135	Transistor	2SD2216R-TX	
Q25	XU0193	Transistor	RN1107 TE85L	
Q26	XT0095	Transistor	2SC4081 T106R	
Q27	XU0192	Transistor	RN2107 TE85L	
Q28	XT0135	Transistor	2SD2216R-TX	
Q29	XU0195	Transistor	RN1104 TE85L	
Q30	XU0194	Transistor	RN2111 TE85L	
Q31	XU0192	Transistor	RN2107 TE85L	
R1	RK3030	Chip R	MCR03EZHJ221	
R2	RK3030	Chip R	MCR03EZHJ221	
R3	RK3034	Chip R	MCR03EZHJ471	
R4	RK3050	Chip R	MCR03EZHJ103	
R5	RK3022	Chip R	MCR03EZHJ470	
R6	RK3042	Chip R	MCR03EZHJ222	
R7	RK3046	Chip R	MCR03EZHJ472	
R8	RK3022	Chip R	MCR03EZHJ470	
R9	RK3030	Chip R	MCR03EZHJ221	
R10	RK3062	Chip R	MCR03EZHJ104	
R11	RK3049	Chip R	MCR03EZHJ822	
R12	RK3062	Chip R	MCR03EZHJ104	
R13	RK3018	Chip R	MCR03EZHJ220	
R14	RK3046	Chip R	MCR03EZHJ472	
R15	RK3044	Chip R	MCR03EZHJ332	
R16	RK3062	Chip R	MCR03EZHJ104	
R17	RK3034	Chip R	MCR03EZHJ471	
R18	RK3026	Chip R	MCR03EZHJ101	
R19	RK3062	Chip R	MCR03EZHJ104	
R20	RK3042	Chip R	MCR03EZHJ222	
R21	RK3037	Chip R	MCR03EZHJ821	
R22	RK3050	Chip R	MCR03EZHJ103	
R23	RK3058	Chip R	MCR03EZHJ473	
R24	RK3058	Chip R	MCR03EZHJ473	
R25	RK3062	Chip R	MCR03EZHJ104	
R26	RK3053	Chip R	MCR03EZHJ183	
R27	RK3054	Chip R	MCR03EZHJ223	
R28	RK3052	Chip R	MCR03EZHJ153	
R28	RK3054	Chip R	MCR03EZHJ223	
R29	RK0002	Chip R	ERJ6GEYJ120V	
R30	RK3034	Chip R	MCR03EZHJ471	
R31	RK3042	Chip R	MCR03EZHJ222	
R32	RK3050	Chip R	MCR03EZHJ103	
R33	RK3030	Chip R	MCR03EZHJ221	
R34	RK3050	Chip R	MCR03EZHJ103	
R35	RK3046	Chip R	MCR03EZHJ472	
R36	RK3022	Chip R	MCR03EZHJ470	
R37	RK3050	Chip R	MCR03EZHJ103	
R38	RK3039	Chip R	MCR03EZHJ122	
R39	RK3066	Chip R	MCR03EZHJ224	
R40	RK3050	Chip R	MCR03EZHJ103	
R41	RK3018	Chip R	MCR03EZHJ220	
R42	RK3042	Chip R	MCR03EZHJ222	
R43	RK3038	Chip R	MCR03EZHJ102	
R44	RK3037	Chip R	MCR03EZHJ821	
R45	RK3044	Chip R	MCR03EZHJ332	
R46	RK3062	Chip R	MCR03EZHJ104	
R47	RK3030	Chip R	MCR03EZHJ221	
R48	RK3042	Chip R	MCR03EZHJ222	
R49	RK3037	Chip R	MCR03EZHJ821	
R50	RK3020	Chip R	MCR03EZHJ330	
R51	RK3062	Chip R	MCR03EZHJ104	
R52	RK3038	Chip R	MCR03EZHJ102	
R53	RK3076	Chip R	MCR03EZHJ155	

T.E.EAH  
TFH.TLH  
T.E.EAH

Ref. No.	Parts No.	Description	Parts Name	Ver
R54	RK3074	Chip R	MCR03EZHJ105	
R55	RK3022	Chip R	MCR03EZHJ470	
R56	RK3042	Chip R	MCR03EZHJ222	
R57	RK3074	Chip R	MCR03EZHJ105	
R58	RK3022	Chip R	MCR03EZHJ470	
R59	RK3074	Chip R	MCR03EZHJ105	
R60	RK3074	Chip R	MCR03EZHJ105	
R61	RK3050	Chip R	MCR03EZHJ103	
R62	RK3030	Chip R	MCR03EZHJ221	
R63	RK3050	Chip R	MCR03EZHJ103	
R64	RK3059	Chip R	MCR03EZHJ563	
R65	RK3058	Chip R	MCR03EZHJ473	
R66	RK3058	Chip R	MCR03EZHJ473	
R67	RK3076	Chip R	MCR03EZHJ155	
R68	RK3059	Chip R	MCR03EZHJ563	
R69	RK3074	Chip R	MCR03EZHJ105	
R70	RK3054	Chip R	MCR03EZHJ223	
R71	RK3057	Chip R	MCR03EZHJ393	T.E.EAH
R71	RK3058	Chip R	MCR03EZHJ473	TFH.TLH
R72	RK3054	Chip R	MCR03EZHJ223	
R73	RK3050	Chip R	MCR03EZHJ103	
R74	RK3044	Chip R	MCR03EZHJ332	
R75	RK3058	Chip R	MCR03EZHJ473	
R76	RK3050	Chip R	MCR03EZHJ103	
R77	RK3058	Chip R	MCR03EZHJ473	
R78	RK3054	Chip R	MCR03EZHJ223	
R79	RK3050	Chip R	MCR03EZHJ103	
R80	RK3046	Chip R	MCR03EZHJ472	
R81	RK3062	Chip R	MCR03EZHJ104	
R82	RK3046	Chip R	MCR03EZHJ472	
R83	RK3050	Chip R	MCR03EZHJ103	
R84	RK3036	Chip R	MCR03EZHJ681	
R85	RK3022	Chip R	MCR03EZHJ470	
R86	RK3050	Chip R	MCR03EZHJ103	
R87	RK3038	Chip R	MCR03EZHJ102	
R88	RK3050	Chip R	MCR03EZHJ103	
R89	RK3032	Chip R	MCR03EZHJ331	
R90	RK3044	Chip R	MCR03EZHJ332	
R91	RK3062	Chip R	MCR03EZHJ104	
R92	RK3058	Chip R	MCR03EZHJ473	
R93	RK3032	Chip R	MCR03EZHJ331	
R94	RK3050	Chip R	MCR03EZHJ103	
R95	RK3050	Chip R	MCR03EZHJ103	
R96	RK3058	Chip R	MCR03EZHJ473	
R97	RK3052	Chip R	MCR03EZHJ153	
R98	RK3050	Chip R	MCR03EZHJ103	
R99	RK3041	Chip R	MCR03EZHJ182	
R100	RK3066	Chip R	MCR03EZHJ224	
R101	RK3050	Chip R	MCR03EZHJ103	
R102	RK3066	Chip R	MCR03EZHJ224	
R103	RK3052	Chip R	MCR03EZHJ153	
R104	RK3048	Chip R	MCR03EZHJ682	
R105	RK3054	Chip R	MCR03EZHJ223	
R106	RK3050	Chip R	MCR03EZHJ103	
R107	RK3050	Chip R	MCR03EZHJ103	
R108	RK3014	Chip R	MCR03EZHJ100	
R109	RK3062	Chip R	MCR03EZHJ104	
R110	RK3066	Chip R	MCR03EZHJ224	
R111	RK3038	Chip R	MCR03EZHJ102	
R112	RK3051	Chip R	MCR03EZHJ123	
R113	RK3032	Chip R	MCR03EZHJ331	
R114	RK3062	Chip R	MCR03EZHJ104	
R115	RK1018	Chip R	ERJ8GEYJ101V	
R116	RK3074	Chip R	MCR03EZHJ105	
R117	RK3062	Chip R	MCR03EZHJ104	
R118	RK3045	Chip R	MCR03EZHJ392	
R119	RK3057	Chip R	MCR03EZHJ393	
R120	RK3061	Chip R	MCR03EZHJ823	
R121	RK3055	Chip R	MCR03EZHJ273	
R122	RK3062	Chip R	MCR03EZHJ104	
R123	RK3058	Chip R	MCR03EZHJ473	
R124	RK3063	Chip R	MCR03EZHJ124	
R125	RK3072	Chip R	MCR03EZHJ684	
R126	RK3056	Chip R	MCR03EZHJ333	
R127	RK3054	Chip R	MCR03EZHJ223	
R128	RK3056	Chip R	MCR03EZHJ333	
R129	RK3058	Chip R	MCR03EZHJ473	
R130	RK3038	Chip R	MCR03EZHJ102	
R131	RK3022	Chip R	MCR03EZHJ470	
R132	RK3050	Chip R	MCR03EZHJ103	
R133	RK3014	Chip R	MCR03EZHJ100	
R134	RK3058	Chip R	MCR03EZHJ473	
R135	RK3074	Chip R	MCR03EZHJ105	
R136	RK3050	Chip R	MCR03EZHJ103	

Ref. No.	Parts No.	Description	Parts Name	Ver
R137	RK3062	Chip R	MCR03EZHJ104	
R138	RK3069	Chip R	MCR03EZHJ394	
R139	RK3038	Chip R	MCR03EZHJ102	
R140	RK3065	Chip R	MCR03EZHJ184	
R141	RK3061	Chip R	MCR03EZHJ823	
R142	RK3058	Chip R	MCR03EZHJ473	
R143	RK3050	Chip R	MCR03EZHJ103	
R144	RK3062	Chip R	MCR03EZHJ104	
R145	RK3062	Chip R	MCR03EZHJ104	
R146	RK3040	Chip R	MCR03EZHJ152	
R147	RK3070	Chip R	MCR03EZHJ474	
R148	RK3052	Chip R	MCR03EZHJ153	
R149	RK3046	Chip R	MCR03EZHJ472	
R150	NC			
R151	RK3038	Chip R	MCR03EZHJ102	
R152	RK3046	Chip R	MCR03EZHJ472	
R153	RK3038	Chip R	MCR03EZHJ102	
R154	RK3050	Chip R	MCR03EZHJ103	
R155	RK3046	Chip R	MCR03EZHJ472	
R156	RK3048	Chip R	MCR03EZHJ682	
R157	RK3062	Chip R	MCR03EZHJ104	
R158	RK3055	Chip R	MCR03EZHJ273	
R158	RK3056	Chip R	MCR03EZHJ333	
R159	RK3038	Chip R	MCR03EZHJ102	
R160	RK3074	Chip R	MCR03EZHJ105	
R161	RK3069	Chip R	MCR03EZHJ394	
R162	RK3060	Chip R	MCR03EZHJ683	
R163	RK3050	Chip R	MCR03EZHJ103	
R164	RK3050	Chip R	MCR03EZHJ103	
R165	RK3048	Chip R	MCR03EZHJ682	
R166	RK3038	Chip R	MCR03EZHJ102	
R167	RK3048	Chip R	MCR03EZHJ682	
R168	RK3038	Chip R	MCR03EZHJ102	
R169	RK3074	Chip R	MCR03EZHJ105	
R170	RK3062	Chip R	MCR03EZHJ104	
R171	RK3062	Chip R	MCR03EZHJ104	
R172	RK3001	Chip R	MCR03EZHJ000	
R173	RK3066	Chip R	MCR03EZHJ224	
R174	RK3066	Chip R	MCR03EZHJ224	
R175	RK3062	Chip R	MCR03EZHJ104	
R176	RK3074	Chip R	MCR03EZHJ105	
R177	RK3066	Chip R	MCR03EZHJ224	
R178	RK3062	Chip R	MCR03EZHJ104	
R179	RK3062	Chip R	MCR03EZHJ104	
R180	RK3046	Chip R	MCR03EZHJ472	
R181	RK3058	Chip R	MCR03EZHJ473	
R182	RK3046	Chip R	MCR03EZHJ472	
R183	NC			
R184	RK3054	Chip R	MCR03EZHJ223	
R185	NC			
R186	NC			
R187	NC			
R188	RK3026	Chip R	MCR03EZHJ101	
R189	RK3074	Chip R	MCR03EZHJ105	
R190	RK3058	Chip R	MCR03EZHJ473	
R191	RK3050	Chip R	MCR03EZHJ103	
R192	RK3059	Chip R	MCR03EZHJ563	
R193	RK3063	Chip R	MCR03EZHJ124	
R194	RK3060	Chip R	MCR03EZHJ683	
R195	RK3050	Chip R	MCR03EZHJ103	
R196	RK3067	Chip R	MCR03EZHJ274	
R197	RK3050	Chip R	MCR03EZHJ103	
R198	RK3050	Chip R	MCR03EZHJ103	
R199	RK2042	Chip R	MCR18EZHJ152	
R200	RK3054	Chip R	MCR03EZHJ223	
R201	RK3057	Chip R	MCR03EZHJ393	
R202	RK3045	Chip R	MCR03EZHJ392	
R203	RK3050	Chip R	MCR03EZHJ103	
R204	RK3050	Chip R	MCR03EZHJ103	
R205	RK3050	Chip R	MCR03EZHJ103	
R206	RK3050	Chip R	MCR03EZHJ103	
R207	RK3052	Chip R	MCR03EZHJ153	
R208	NC			
SW17	UU0030	Switch	EVQPJ005	
SW18	UU0030	Switch	EVQPJ005	
TC1	CT0012	Trimmer	CTZ3S-10A-W1-P	
VR1	RH0140	Volume	MVR22HXBRN472	
W1	MACL07AA	Wire	#30A02-070-02	
W2	MACL07AA	Wire	#30A02-070-02	
W3	MACLH2GG	Wire	#30AH1-025-H1	
X1	XQ0112	Crystal	UM-5 21.250MHZ	
X2	XQ0077	Crystal	38C 3.686400MHZ	
XF1	XF0041	MCF	UM5 21.7M 21R15A5	T.E
XF2	XF0041	MCF	UM5 21.7M 21R15A5	

Ref. No.	Parts No.	Description	Parts Name	Ver
Mechanical Parts				
	AF0012	Screw	OPH M2+4 FE/ZN3	
	AF0029	Screw	OPH 2+9 FE/N 3	
	AK0001		OPH B2+4 FE/N 3	
	AN0012	Nut	RND N7X0.75 BR/B.ZN	
	DG0035		LCD LIGHT	
	DP0126		LCD PANLE DJ195	
	ES0011AZ	Speaker	036M9014	
	FF0029		Sheet	
	FG0274		DC CAP	
	FG0285		16 KEY RUBBER DJ195	
	FG0286		JACK CAP DJ195	
	FG0289		TERMINAL RUBBER 195	
	FG0290		PTT RUBBER DJ195	
	FG0291		LCD RUBBER CONNECT.	
	FM0176		PLUS TERMINAL DJ195	
	FM0177		RADIATIVE PLATE 195	
	FM0178		DJ195	
	FM0179		ANTENNA EARTH DJ195	
	FP0142		BLIND SHEET DJ195	
	KZ0098		FRONT CASE DJ195	
	MACLH2GG	Wire	#30AH1-025-H1	
	NK0068		DIAL KNOB DJ195	
	RD0108		J1/6Z	
	SS0092		CHASSIS DJ195	
	ST0063		LCD HOLDER DJ195	
	TG0033		SP HIMELON DJ195	
	TL0022		REFLECTIVE SHEET 195	
	TS0142		VCO case XH655	
	TW0020		W.PROOF A XH720	
	UE0029A		ANT.CONNECT.DJ460	

Ref. No.	Parts No.	Description	Parts Name	Ver
	UR0019	Dial	RH70N00E20 (RY-6320)	
	YX0024		LCD TAPE DJ195	
Packing Parts				
	EA57		Antenna	T.E.EAH
	EA58		Antenna	TFH.TLH
	PR0309		CE label	E.EAH
	EBP-48N		EBP-48N	
	HK0465		Pacage	
	HM0189		Carton 10	
	HU0150		Inner C	
	HU0151		Inner 5	
	BH0011		Belt clip	
	BB0009Y		Strap	
	HP0003		Protection Bag 5*75*110	
	PR0237		FCC label	
	DS0388A		Spec.sheet	EEAH.TFH.TLH
	DS0411		Spec.sheet DJ195T	T
	PS0313A		Instruction Manual	
	HH0061		Air cap	
	EDC93		Wall charger EDC-93	T
	EDC94		Wall charger EDC-94	EEAH.TFH.TLH
	PH0009A		Warranty	T
	PT0004A		Serial No. Carton	
	PK0076		Schematic Diagram	
	PR0421		Serial No. label	
	DS0388A		Spec. sheet with out Serial	EEAH.TFH.TLH
	DS0411		Spec. sheet DJ195 with out Serial	T

# ADJUSTMENT

## 1) Required Test Equipment

The following items are required to adjust radio parameters:

### 1. Regulated power supply

Supply voltage: 5-14V DC  
Current: 3A or more

### 2. Digital multimeter

Voltage range: FS = Approx. 20V  
Current: 10A or more  
Input resistance: High impedance

### 3. Oscilloscope

Measurable frequency: Audio frequency

### 4. Audio dummy load

Impedance: 8Ω  
Dissipation: 1W or more  
Jack: 3.5mmΦ

### 5. SSG

Output frequency: 200MHz or more  
Output level: -20dBu/0.1uV -120dBu/1V  
Modulation: FM

### 6. Spectrum Analyzer

Measuring range: Up to 2GHz or more

### 7. Power meter

Measurable frequency: Up to 200MHz  
Impedance: 50Ω, unbalanced  
Measuring range: 0.1W -10W

### 8. Audio voltmeter

Measurable frequency: Up to 100kHz  
Sensitivity: 1mV to 10V

### 9. Audio generator

Output frequency: 67Hz to 10kHz  
Output impedance: 600Ω, unbalanced

### 10. Distortion meter/SINAD meter

Measurable frequency: 1kHz  
Input level: Up to 40dB  
Distortion: 1% - 100%

### 11. Frequency counter

Measurable frequency: Up to 200MHz  
Measurable stability: Approx. +/-0.1ppm

## 12.Linear detector

Measurable frequency: Up to 200MHz  
Characteristics: Flat  
CN: 60dB or more

### **Note**

- Standard modulation: 1kHz +/-3.5kHz/DEV
- Reference sensitivity: 12dB SINAD
- Specified audio output level: 200mW at 8Ω
- Standard audio output level: 50mW at 8Ω
- Use an RF cable (3D2W:1m) for test equipment.
- Attach a fuse to the RF test equipment.
- All SSG outputs are indicated by EMF.
- Supply voltage for the transceiver: 13.8VDC

## 2) Adjustment Mode

The DJ-195 does not require a serviceworker to manipulate the components on the printed-circuit board, except the trimmer when adjusting reference frequency and deviation. Most of the adjustments for the transceiver are made by using the keys on it while the unit is in the adjustment mode. Because the adjustment mode temporarily uses the channels, frequency must be set on each channel before adjustments can be made. For instructions on how to program the channels, see the "DJ-195 INSTRUCTION MANUAL" which came with the product. In consideration of the radio environment, the frequency on each channel must be near the value (+/-1MHz) listed in the table below. To enter the adjustment mode, set key lock and input 490217. Decimal point at 100MHz and 10MHz appears in LCD. (To release the mode, set key-lock and input 490217.)

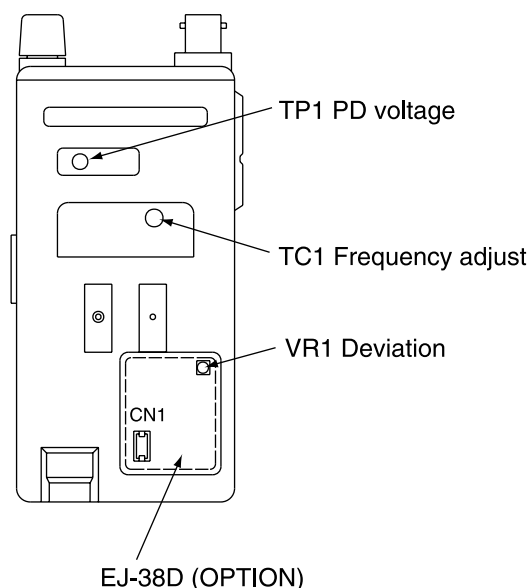

### Channel frequencies used in the adjustment mode

Channel	Channel function	Frequency
1	Reference frequency adjustment	145 MHz
2	High power adjustment	145 MHz
3	Low power adjustment	145 MHz
4	Minimum frequency sensitivity adjustment	130 MHz
5	Medium frequency sensitivity adjustment	145 MHz
6	Maximum frequency sensitivity adjustment	174 MHz
7	S-meter ( 1 ) adjustment	145 MHz
8	S-meter ( FULL ) adjustment	145 MHz
9	Deviation	145 MHz
10	DTMF ( 1 ) test	145 MHz
11	DTMF ( D ) test	145 MHz
12	Tone 67 Hz test	145 MHz
13	Tone 88.5 Hz test	145 MHz
14	Tone 250.3 Hz test	145 MHz
15	DCS code 255 test	145 MHz
16	Tone burst test	145 MHz
17	Aging ( Not required to use )	145 MHz

### Reference Frequency Adjustment

1. In the adjustment mode, select channel 1 by rotating the main tuning dial.
2. Press the **(PTT)** key to start transmission.
3. Rotate TC1 on the Main board until the value on the frequency counter matches the one displayed on the LCD.
4. On 145.05MHz measure TP1 near the VCO and to obtain  $1.2V+0.1V$  ( If the frequency display is flashing, the PLL is unlocked. )

### High Power Adjustment

1. In the adjustment mode, select channel 2 by rotating the main tuning dial.
2. Hold down the **(PTT)** key to start transmission.
3. While watching the reading of the TX power meter, set the output power to the value closest to 5 W by rotating the main tuning dial.
4. When the **(PTT)** key is released, the output power at that time will be stored as the high power setting.

### Low Power Adjustment

1. In the adjustment mode, select channel 3 by rotating the main tuning dial.
2. Hold down the **(PTT)** key to start transmission.
3. While watching the reading of the TX power meter, set the output power to the value closest to 0.8 W by rotating the main tuning dial.
4. When the **(PTT)** key is released, the output power at that time will be stored as the low power setting.

### Minimum Frequency Sensitivity Adjustment

See "Note on Adjusting the Sensitivity" later in this section.

1. In the adjustment mode, select channel 4 by rotating the main tuning dial.
2. Set the minimum frequency sensitivity rotating the main tuning dial, while F appears after the **(FUNC)** key is pressed.

### Medium Frequency Sensitivity Adjustment

See "Note on Adjusting the Sensitivity" later in this section.

1. In the adjustment mode, select channel 5 by rotating the main tuning dial.
2. Set the medium frequency sensitivity rotating the main tuning dial, while F appears after the **(FUNC)** key is pressed.

### Maximum Frequency Sensitivity Adjustment

See "Note on Adjusting the Sensitivity" later in this section.

1. In the adjustment mode, select channel 6 by rotating the main tuning dial.
2. Set the maximum frequency sensitivity rotating the main tuning dial, while F appears after the **(FUNC)** key pressed.

### S-meter (1) Adjustment

1. In the adjustment mode, select channel 7 by rotating the main tuning dial. The S-meter will show a single circle ( ● )
2. Enter "0"dBu(EMF) with the transceiver tester (SSG).
3. Press the F key. The transceiver beeps indicating the new setting has been stored successfully.

### S-meter (FULL)

1. In the adjustment mode, select channel 8 by rotating the main tuning dial. The S-meter will show all six circles ( ●●●●●● )
2. Enter "+20"dBu (EMF) with the transceiver tester (SSG).
3. Press the  key. The transceiver beeps indicating the new setting has been stored successfully.

### Deviation

1. In the adjustment mode, select channel 9 by rotating the main tuning dial.
2. Input a 50mVrms, 1KMz signal with your transceiver tester through the external microphone jack.
3. With the tester, put the transceiver in the transmission mode.
4. Rotate the VR1 on the printed-circuit board of the transceiver until the deviation is set to 4.5KHz.

### DTMF (1) Test

This function is only for checking the DTMF code, not adjusting it.

1. In the adjustment mode, select channel 10 by rotating the main tuning dial.
2. Press the  key. DTMF code "1" is automatically sent and you will hear the monitoring tone from the speaker.
3. Check the deviation with the transceiver tester.

### DTMF (D) Test

1. In the adjustment mode, select channel 11 by rotating the main tuning dial.
2. Press the  key. DTMF code "D" is automatically sent and you will hear the monitoring tone from the speaker.
3. Check the deviation with the transceiver tester.

### Tone 67Hz Test

This function is only for checking the tone encoder, not adjusting it.

1. In the adjustment mode, select channel 12 by rotating the main tuning dial.
2. Press the  key. A 67Hz tone is automatically sent.
3. Check the deviation with the transceiver tester.

### Tone 88.5Hz Test

1. In the adjustment mode, select channel 13 by rotating the main tuning dial.
2. Press the  key. An 88.5Hz tone is automatically sent.
3. Check the deviation with the transceiver tester.

### Tone 250.3Hz Test

1. In the adjustment mode, select channel 14 by rotating the main tuning dial.
2. Press the **(PTT)** key. A 250.3Hz tone is automatically sent.
3. Check the deviation with the transceiver tester.

### DCS Code 225 Test

1. In the adjustment mode, select channel 15 by rotating the main tuning dial.
2. Press the **(PTT)** key. An 255 DCS code is automatically sent.
3. Check the deviation with the transceiver tester.

### Tone Burst Test

This function is only for checking the tone burst, not adjusting it.

1. In the adjustment mode, select channel 16 by rotating the main tuning dial.
2. Press the **(PTT)** key. A 1750Hz tone burst is automatically sent.
3. Check the deviation with the transceiver tester.

### Aging

Perform this aging test only when necessary.

1. In the adjustment mode, select channel 17 by rotating the main tuning dial.  
The transceiver automatically repeats transmission for a minute and reception for another minute.

### Note on Adjusting Sensitivity

Sensitivity is adjusted by applying the optimum voltage from the CPU to the varicap of the tuning circuit.

1. Program any frequency within 145MHz +/- 1MHz on memory channel 5.
2. To enter the adjustment mode, set key lock and input 490217. Decimal point at 100MHz and 10MHz appears in LCD. (To release the mode, set key lock and input 490217).
3. Select channel 5 by rotating the main tuning dial.
4. Press the **(F)** key and, while the F appears, rotate the main tuning dial. Set the adjustment data to “\*\*” for maximizing the sensitivity (“\*\*” appears in the channel number area on the LCD).
5. Press the **(F)** key.
6. In the key lock mode, Input 490217. Decimal point at 100MHz and 10MHz disappear. Turn the power OFF. The transceiver is in the normal status.





# SCHEMATIC DIAGRAM

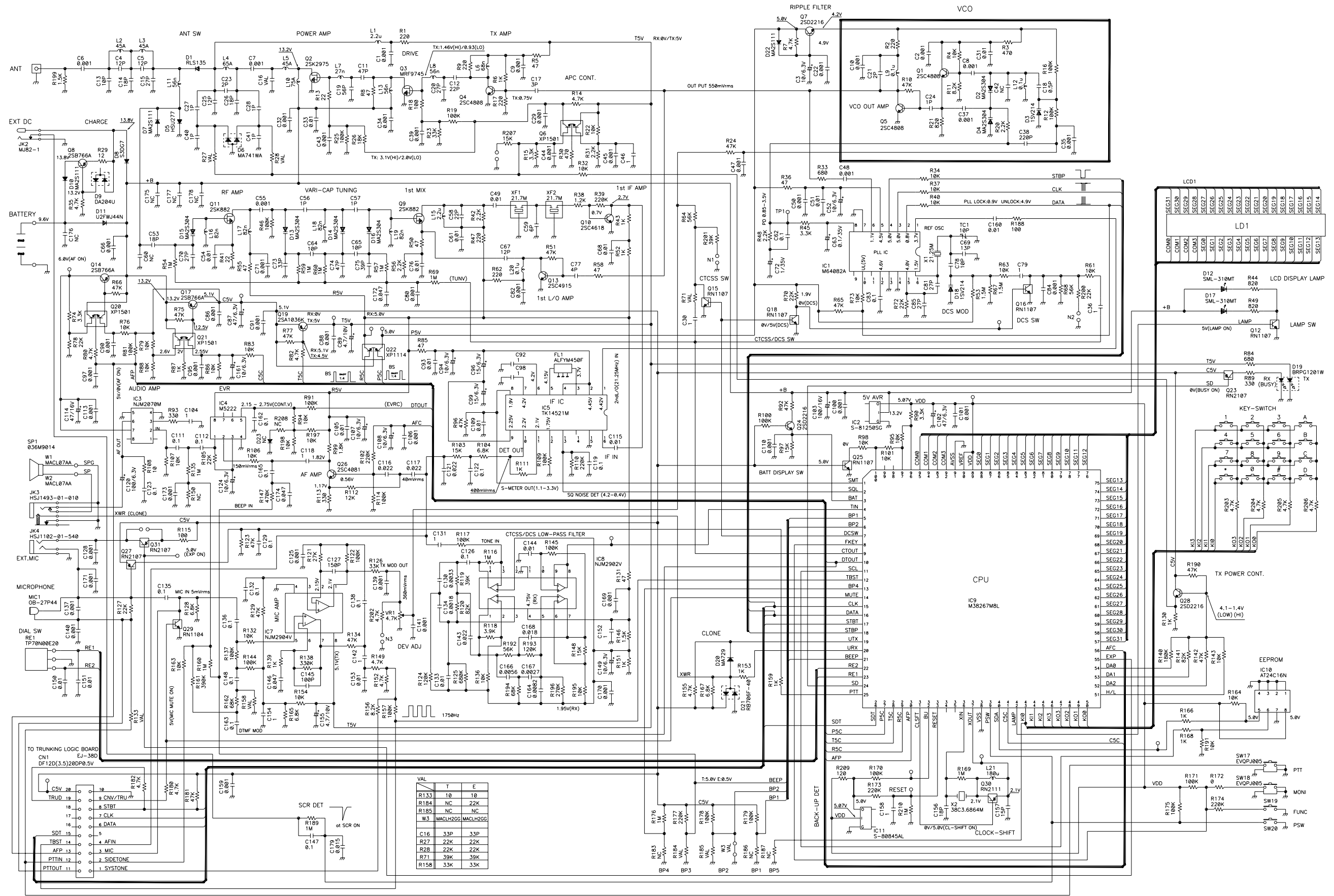

# BLOCK DIAGRAM

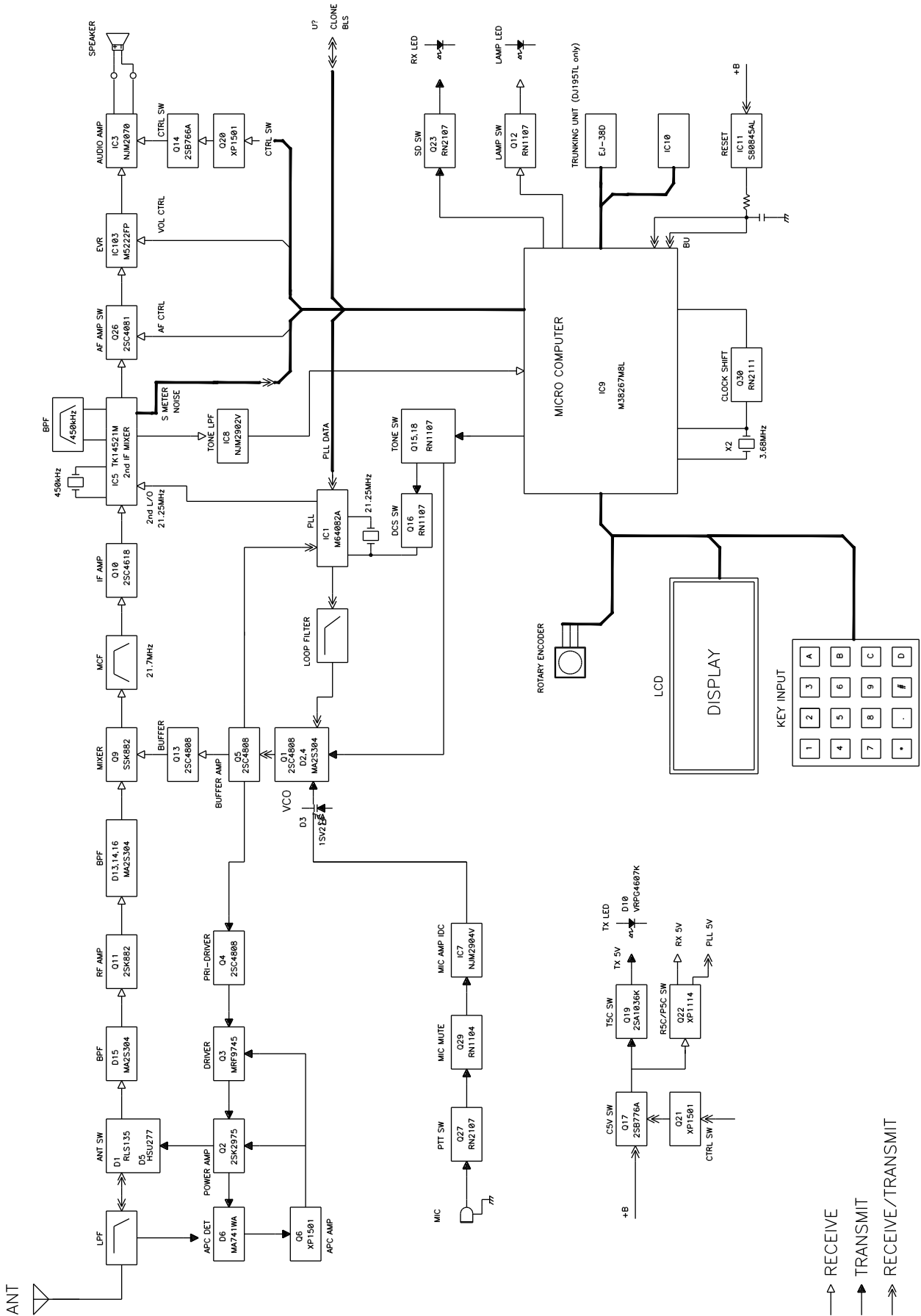

- RECEIVE
- TRANSMIT
- RECEIVE/TRANSMIT





# ALINCO, INC.

**Head Office :** "TWIN 21" MID Tower Building 25F  
1-61, 2-Chome, Shiromi, Chuo-ku, Osaka 540-8580 Japan  
Phone: 06-6946-8150 Fax: 06-6946-8175 Telex: 63086  
E-mail: 101243.1446@compuserve.com

**U.S.A. :** 438 Amapola Ave., Suite 130, Torrance, CA 90501-6201, U.S.A.  
Phone: 310-618-8616 Fax: 310-618-8758  
<http://www.alinco.com/>

**Germany :** Eschborner Landstrasse 55, 60489 Frankfurt am Main, Germany  
Phone: 069-786018 Fax: 069-789-60766

Dealer/Distributor