

CIRCUIT DESCRIPTION DJ-296T

1) Receiver System

The receiver system is a double superheterodyne system with a 30.85 MHz first IF and a 455 kHz second IF.

1. Front End

The received signal at any frequency in the 216.00 to 249.995 MHz range is passed through the low-pass filter (L2, L3, L8, C2, C9, C10, C11, C62 and C189), high-pass filter (C56, C57, C58, C61, L22, L25 and D15), and amplified by the RF amplifier (Q9). The signal from Q9 is then passed through the tuning circuit (C12, C14, C65, C66, L19, L20, L21, D12, D13 and D14) and converted into 30.85 MHz by the mixer (Q10). The tuning circuit is controlled by the tracking voltage from the CPU (IC9) so that it is optimized for the reception frequency. The local signal from the VCO is passed through the buffer (Q11), and supplied to the source of the mixer (Q10). The radio uses the lower side of the superheterodyne system.

2. IF Circuit

The mixer mixes the received signal with the local signal to obtain the sum of and difference between them. The crystal filter (XF1) selects 30.85 MHz frequency from the results and eliminates the signals of the unwanted frequencies. The first IF amplifier (Q8) then amplifies the signal of the selected frequency.

3. Demodulator Circuit

After the signal is amplified by the first IF amplifier (Q8), it is input to pin 16 of the demodulator IC (IC4). The second local signal of 30.395 MHz, which is oscillated by the internal oscillation circuit in IC4 and crystal (X2). Then, these two signals are mixed by the internal mixer in IC4 and the result is converted into the second IF signal with a frequency of 455kHz. The second IF signal is output from pin 3 of IC4 to the ceramic filter (FL1), where the unwanted frequency band of that signal is eliminated, and the resulting signal is sent back to the IC4 through pin 5.

The second IF signal input via pin 5 is demodulated by the internal limiter amplifier and quadrature detection circuit in IC4, and output as an audio signal through pin 10.

4. Audio Circuit

The audio signal from pin 10 of IC4 is compensated to the audio frequency characteristics in the

ADJUSTMENT DJ296T

1) Required Test Equipment

The following items are required to adjust radio parameters:

1. Regulated power supply	Supply voltage:	5 - 14 VDC
	Current:	3A or more
2. Digital multimeter	Voltage range:	FS = Approx. 20V
	Current:	10A or more
	Input resistance:	High impedance
3. Oscilloscope	Measurable frequency:	Audio frequency
4. Audio dummy load	Impedance:	8 ohm
	Dissipation:	1W or more
	Jack:	3.5 mm
5. SSG	Output frequency:	500MHz or more
	Output level:	-20dBu/0.1uV - 120dBu/1V
	Modulation:	AM / FM
6. Spectrum Analyzer	Measuring range:	Up to 2 GHz or more
7. Power meter	Measurable frequency:	Up to 500MHz
	Impedance:	50 ohm, unbalanced
	Measuring range:	0.1W - 10W
8. Audio voltmeter	Measurable frequency:	Up to 100kHz
	Sensitivity:	1mV to 10V
9. Audio generator	Output frequency:	67Hz to 10kHz
	Output impedance:	600ohm, unbalanced
10. Distortion /SINAD meter	Measurable frequency:	1kHz
	Input level:	Up to 40dB
	Distortion:	1% - 100%
11. Frequency counter	Measurable frequency:	Up to 500MHz
	Measurable stability:	Approx. +/- 0.1 ppm
12. Linear detector	Measurable frequency:	Up to 500MHz
	Characteristics:	Hat
	CN:	60dB or more

Note

- Standard modulation : 1 kHz +/- 3.5kHz / DEV
- Reference sensitivity 12dB SINAD
- Specified audio output level: 200mW at 8 ohm
- Standard audio output level: 50mW at 8 ohm
- Use an RF cable (3D2W: 1m) for test equipment.
- Attach a fuse to the RF test equipment.

- All SSG outputs are indicated by EMF.
- Supply voltage for the transceiver: 13.8VDC

2) Adjustment Mode

The DJ-296 does not require a serviceperson to manipulate the components on the printed-circuit board, except the trimmer when adjusting reference frequency and deviation. Most of the adjustments for the transceiver are made by using the keys on it while the unit is in the adjustment mode. Because the adjustment mode temporarily uses the channels, frequency must be set on each channel before adjustments can be made. For instructions on how to program the channels, see the “DJ-296 INSTRUCTION MANUAL” which came with the product. In consideration of the radio environment, the frequency on each channel must be near the value (+/- 1 MHz) listed in the table below. To enter the adjustment mode, set key lock and input 490217. Decimal point at 100MHz and 10MHz appears in LCD. (To release the mode, set key lock and input 490217.)

Channel frequencies used in the adjustment mode

Memory Channel	Channel function	Frequency
1	Reference frequency adjustment	223.5 MHz
2	High power adjustment	223.5 MHz
3	Low power adjustment	223.5 MHz
4	Minimum frequency sensitivity adjustment	215 MHz
5	Medium frequency sensitivity adjustment	223.5 MHz
6	Maximum frequency sensitivity adjustment	240 MHz
7	S-meter (1) adjustment	223.5 MHz
8	S-meter (FULL) adjustment	223.5 MHz
9	Deviation	223.5 MHz
10	DTMF (1) test	223.5 MHz
11	DTMF (D) test	223.5 MHz
13	Tone 88.5Hz test	223.5 MHz
15	DCS code 255 test	223.5 MHz
16	Tone burst test	223.5 MHz
17	Aging (Not required to use)	223.5 MHz

Reference Frequency Adjustment

1. In the adjustment mode, select channel 1 by rotating the main tuning dial.
2. Press the PTT key to start transmission.
3. Rotate TC1 on the Main board until the value on the frequency counter matches the one displayed on the LCD.

High Power Adjustment

1. In the adjustment mode, select channel 2 by rotating the main tuning dial.
(“L” at the upper-left of the display disappears).
2. Hold down the PTT key to start transmission.
3. While watching the reading of the TX power meter, set the output power to the value closest to 5 W by rotating VR3 on Main board.

Low Power Adjustment

1. In the adjustment mode, select channel 3 by rotating the main tuning dial.
(“L” appears at the upper-left of the display).
2. Hold down the PTT key to start transmission.
3. While watching the reading of the TX power meter, set the output power to the value closest to 0.8 W by rotating the main tuning dial.
4. When the PTT key is released, the output power at that time will be stored as the low power setting.

Minimum Frequency Sensitivity Adjustment

1. In the adjustment mode, select channel 4 by rotating the main tuning dial.
2. Adjust the minimum frequency sensitivity to the best tuning by rotating the main tuning dial, while F appears after the FUNC key is pressed.

Medium Frequency Sensitivity Adjustment

1. In the adjustment mode, select channel 5 by rotating the main tuning dial.
2. Adjust the medium frequency sensitivity to the best tuning by rotating the main tuning dial, while F appears after the FUNC key is pressed.

Maximum Frequency Sensitivity Adjustment

1. In the adjustment mode, select channel 6 by rotating the main tuning dial.
2. Adjust the maximum frequency sensitivity to the best tuning by rotating the main tuning dial, while F appears after the FUNC key is pressed.

S-meter (1) Adjustment

1. In the adjustment mode, select channel 7 by rotating the main tuning dial.

The S-meter will show a single star.

2. Enter "0" dBu (EMF) with the transceiver tester.
3. Press the F key. The transceiver beeps indicating the new setting has been stored successfully.

S-meter (FULL)

1. In the adjustment mode, select channel 8 by rotating the main tuning dial.

The S-meter will show all six stars.

2. Enter "+20" dBu (EMF) with the transceiver tester.
3. Press the F key. The transceiver beeps indicating the new setting has been stored successfully.

Deviation

1. In the adjustment mode, select channel 9 by rotating the main tuning dial.
2. Input a 50mVrms, 1KHz signal with your transceiver tester through the external microphone jack.
3. With the tester, put the transceiver in the transmission mode.
4. Rotate the VR1 on the printed-circuit board of the transceiver until the deviation is set to 4.5KHz.

DTMF (1) Test

This function is only for checking the DTMF code, not adjusting it.

1. In the adjustment mode, select channel 10 by rotating the main tuning dial.
2. Press the PTT key. DTMF code "1" is automatically sent and you will hear the monitoring tone from the speaker.
3. Check the deviation with the transceiver tester.

DTMF (D) Test

This function is only for checking the DTMF code, not adjusting it.

1. In the adjustment mode, select channel 11 by rotating the main tuning dial.
2. Press the PTT key. DTMF code "D" is automatically sent and you will hear the monitoring tone from the speaker.
3. Check the deviation with the transceiver tester.

Tone 88.5Hz Test

This function is only for checking the tone encoder, not adjusting it.

1. In the adjustment mode, select channel 13 by rotating the main tuning dial.
2. Press the PTT key. An 88.5Hz tone is automatically sent.
3. Check the deviation with the transceiver tester.

DCS Code 255 Test

This function is only for checking the DCS, not adjusting it.

1. In the adjustment mode, select channel 15 by rotating the main tuning dial.
2. Press the PTT key. A 255 DCS code is automatically sent.
3. Check the deviation with the transceiver tester.

Tone Burst Test

This function is only for checking the tone burst, not adjusting it.

1. In the adjustment mode, select channel 16 by rotating the main tuning dial.
2. Press the PTT key. A 1750Hz tone burst is automatically sent.
3. Check the deviation with the transceiver tester.

Aging

Perform this aging test only when necessary.

1. In the adjustment mode, select channel 17 by rotating the main tuning dial.

The transceiver automatically repeats transmission for a minute and reception for another minute.

EXPLODED VIEW DJ-296T

1) Front View

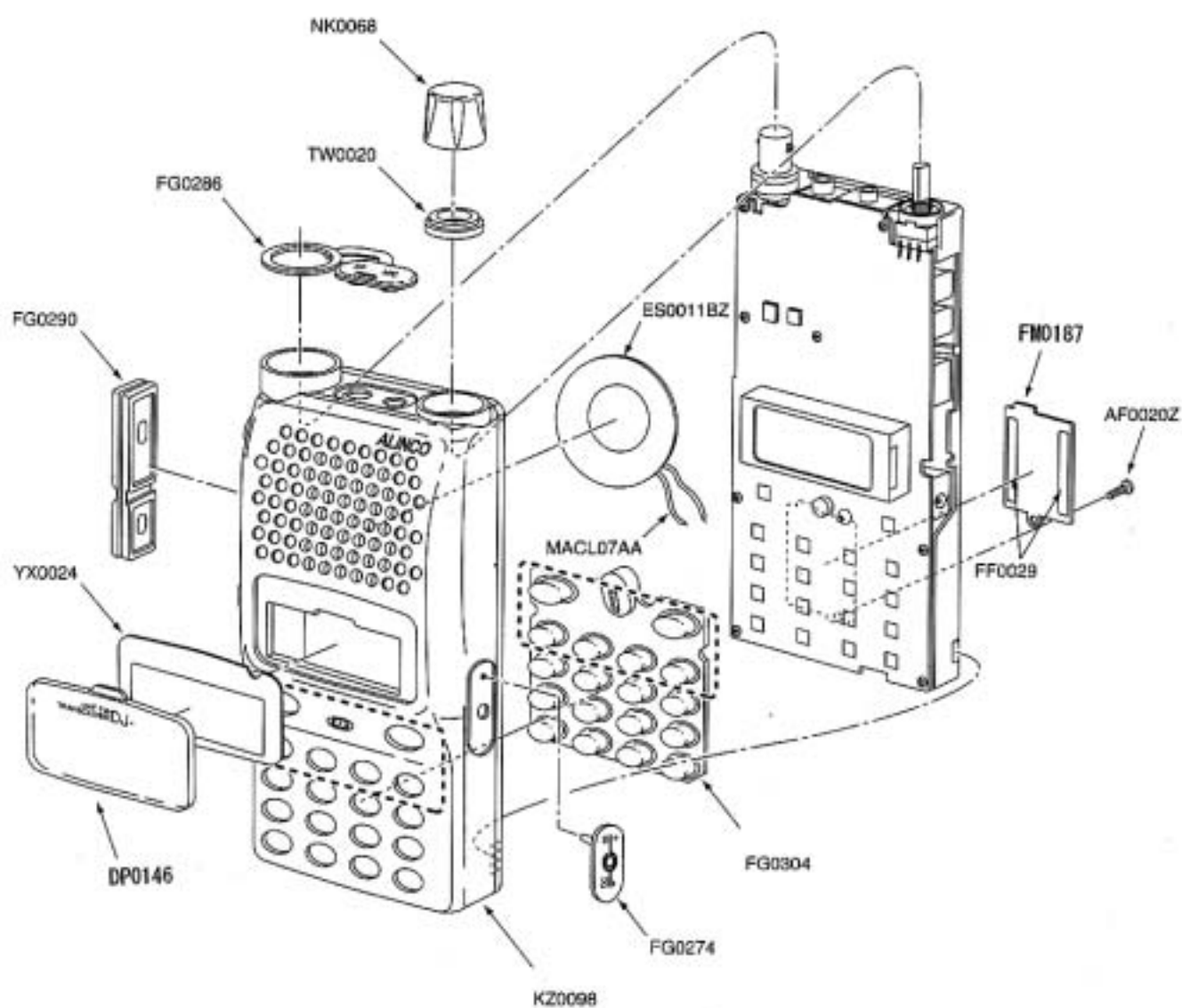

2) Rear View

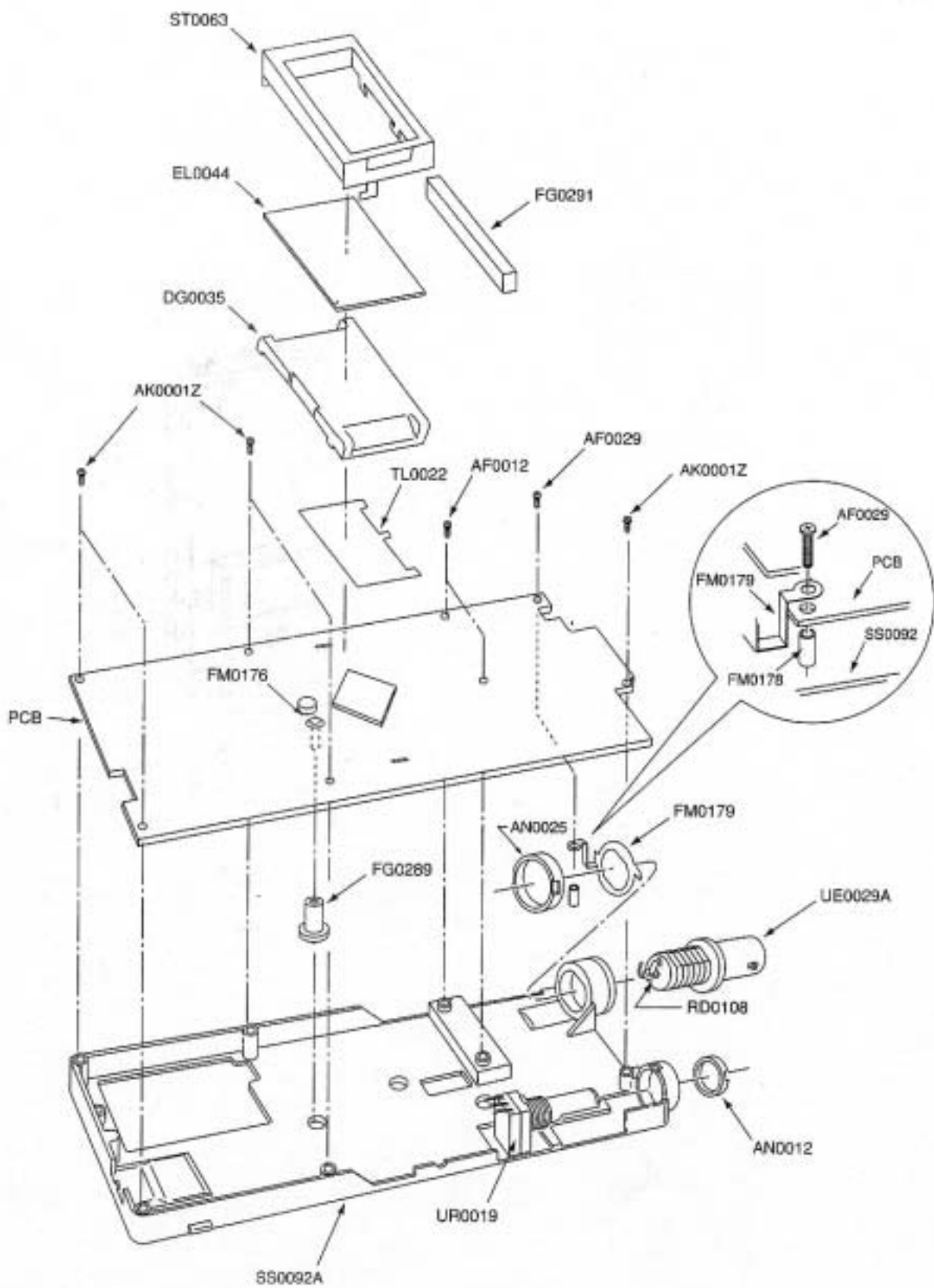

SPECIFICATIONS DJ296T

GENERAL

Frequency coverage	TX: 222.000 – 224.995MHz RX: 216.000 – 249.995MHz
Mode	F3E (FM)
Channel steps	5, 10, 12.5, 15, 20, 25, & 30KHz
Memory channels	160 channels + 1CALL channel
Antenna connector	BNC (50 ohm unbalanced)
Frequency stability	+/- 5 ppm
Microphone input impedance	2K ohm nominal
Power supply requirement	7.0 to 16.0 V DC (negative ground)
Current drain (at 13.8 V DC)	1.2 A (typical) Transmit high at 5W 200 mA (typical) Receive at 280mW 50 mA (typical) standby 20mA (typical) Battery save on
Usable temperature range	-10 to +60 degrees C (14 to 140 dgrees F)
Dimensions	56 (W) * 124 (H) * 40 (D) mm (with EBP-50N)
(Projections not included)	2.2" (W) * 4.88" (H) * 1.57" (D) inches (with EBP-50N)
Weight	Approx.375g (13.2oz) (with EBP-50N)
DTMF	16 Buttons Keypad
Sub audible Tone (CTCSS) encoder/decoder installed	(39tones)
Sub audible Tone (DCS) encoder/decoder installed	(104codes)

TRANSMITTER

Output power	Approx. 4 .5W EBP-50N installed Approx. 5 W 13.8 V DC Approx 0.8 W (LOW)
Modulation system	Variable reactance frequency modulation
Spurious emissions	Less than -60dB
Max. frequency deviation	+/- 5KHz

RECEIVER

Receive system	Double conversion superheterodyne
Intermediate frequencies	1st 30.85MHz / 2nd 455kHz
Sensitivity(12dB SINAD)	Less than -12.0 dBu (0.25uV)
Selectivity	-6 dB : 12KHz or more -60 dB : 26KHz or less
Audio output power	280 mW (typical with an 8 ohm load) 200 mW (8 ohm 10% THD)

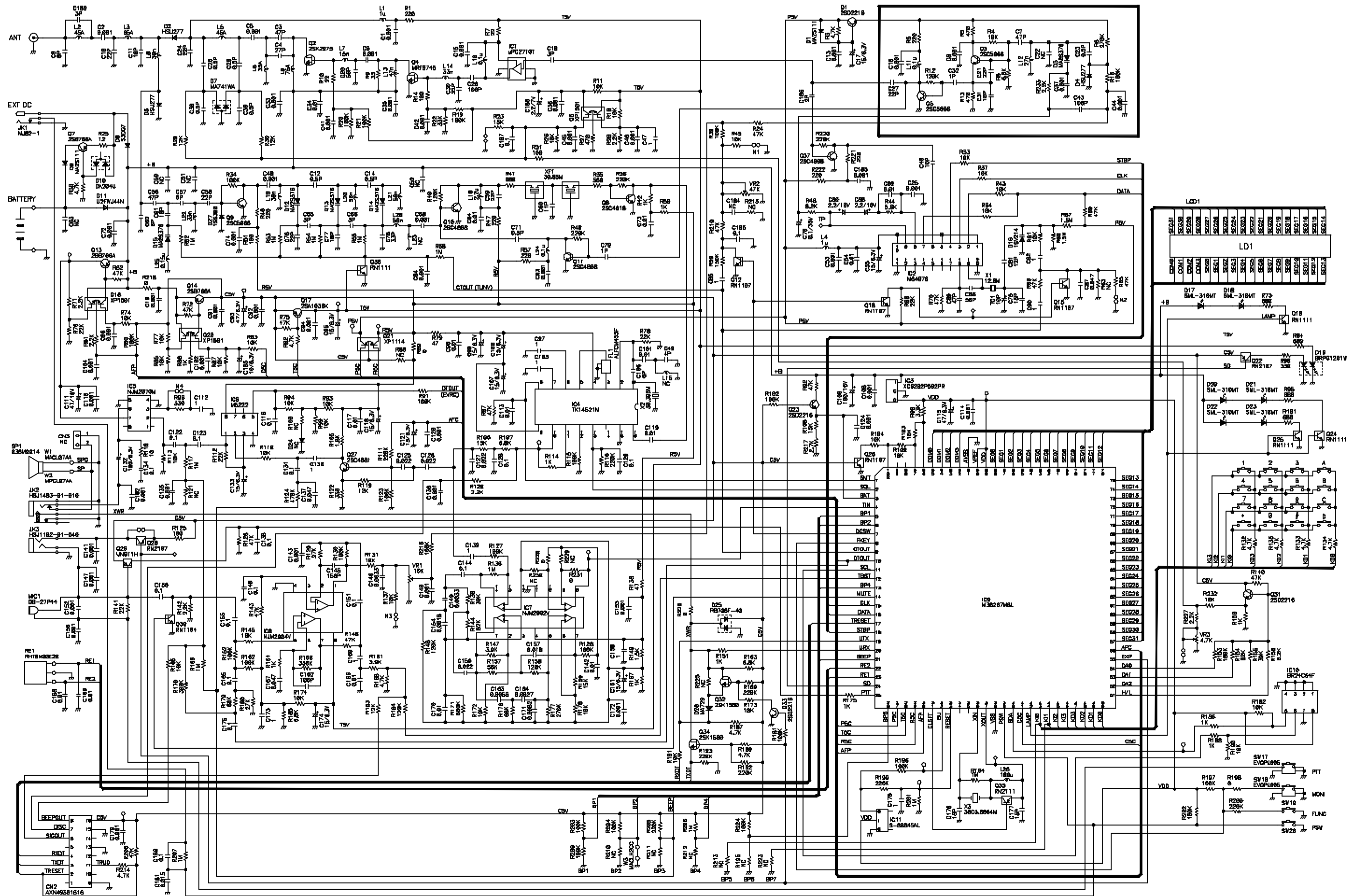

SCHMATIC DIAGRAM DJ296 T

PC BOARD VIEW DJ-296T SIDE B

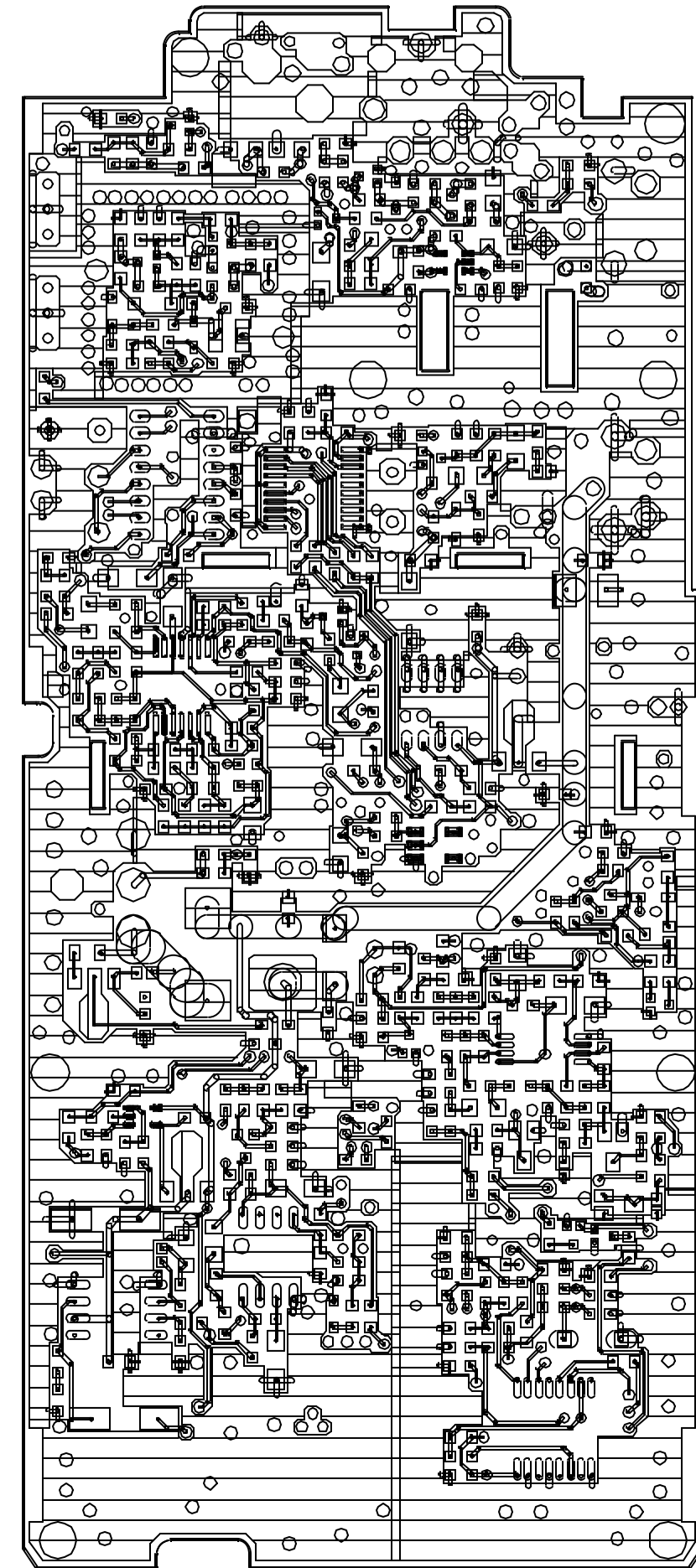
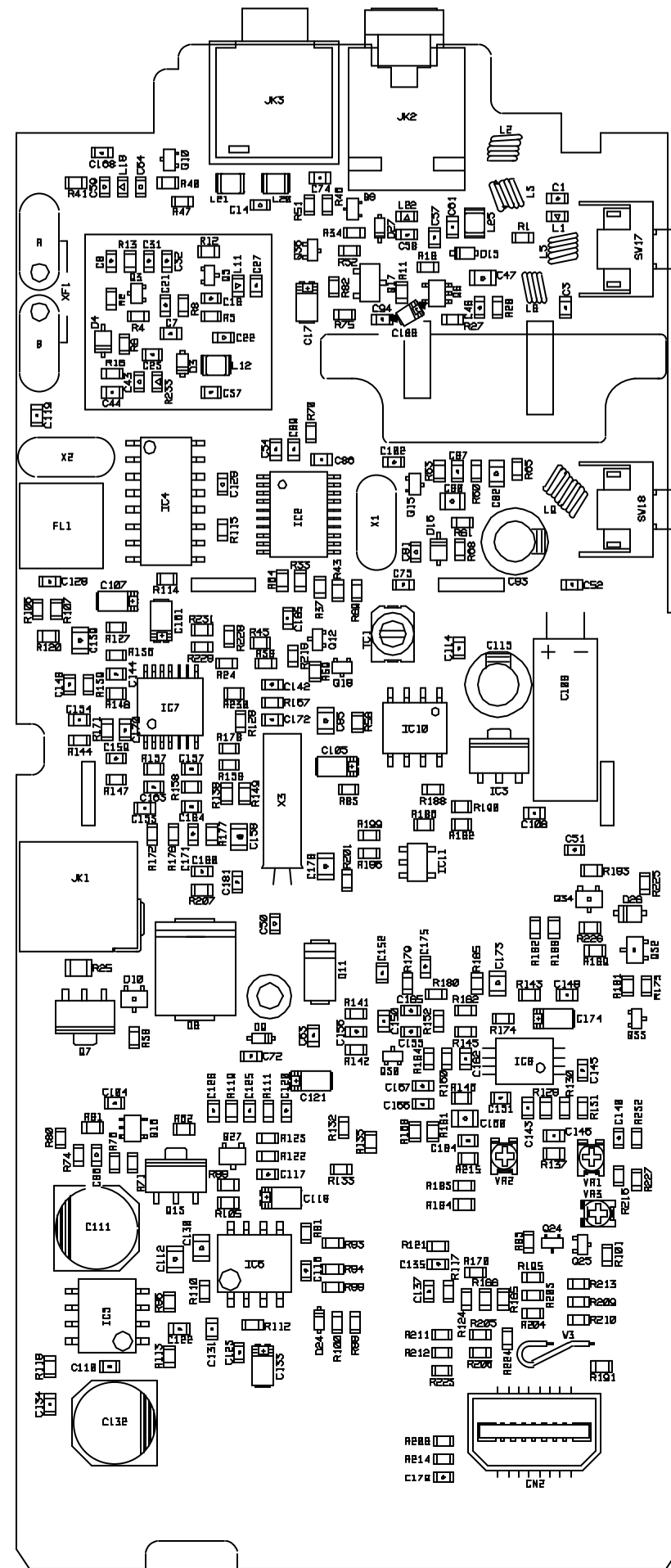

PC BOARD VIEW DJ-296T SIDE A

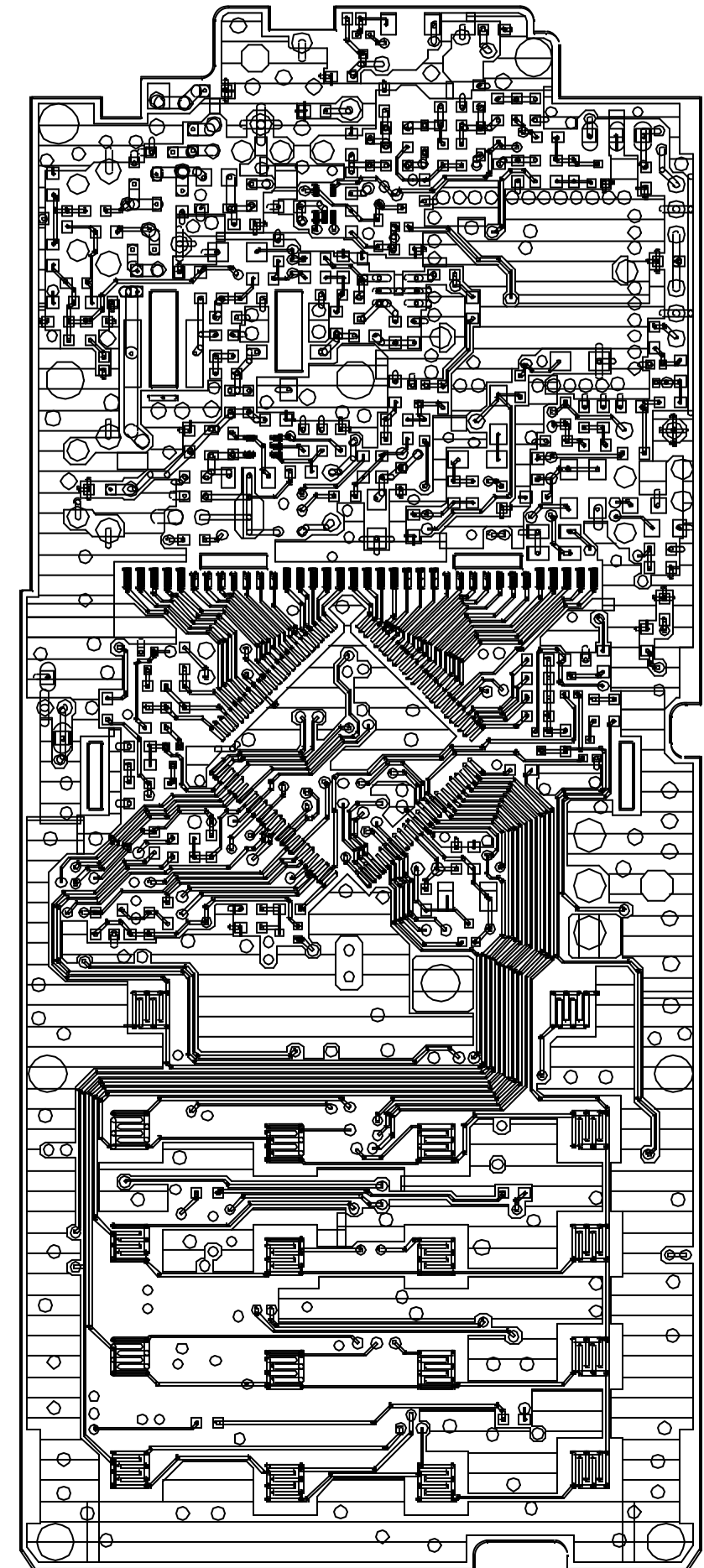
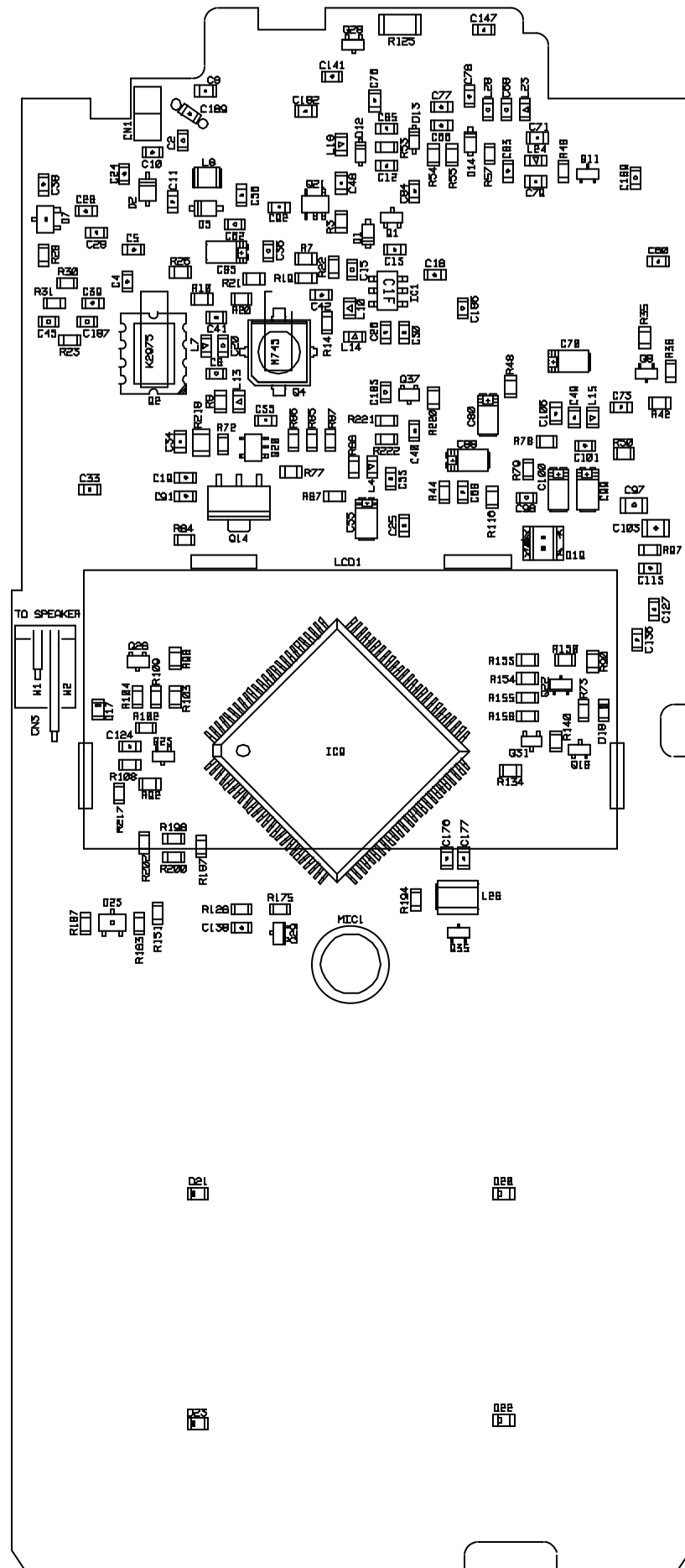

PARTS LIST DJ-296T

	Ref No.	Parts No.	Parts Mame
Electrical Parts	C1	CU3035	C1608JB1H102KT-AS
Electrical Parts	C2	CU3035	C1608JB1H102KT-AS
Electrical Parts	C3	CU3019	C1608CH1H470JT-AS
Electrical Parts	C4	CU3016	C1608CH1H270JT-AS
Electrical Parts	C5	CU3035	C1608JB1H102KT-AS
Electrical Parts	C6	CU3035	C1608JB1H102KT-AS
Electrical Parts	C7	CU3019	C1608CH1H470JT-AS
Electrical Parts	C8	CU3035	C1608JB1H102KT-AS
Electrical Parts	C9	CU3009	C1608CH1H080CT-A
Electrical Parts	C10	CU3015	C1608CH1H220JT-AS
Electrical Parts	C11	CU3014	C1608CH1H180JT-AS
Electrical Parts	C12	CU3001	C1608CH1H0R5CT-AS
Electrical Parts	C13	CU3035	C1608JB1H102KT-AS
Electrical Parts	C14	CU3001	C1608CH1H0R5CT-AS
Electrical Parts	C15	CU3035	C1608JB1H102KT-AS
Electrical Parts	C16	CU3035	C1608JB1H102KT-AS
Electrical Parts	C17	CS0408	6MCM156MATER
Electrical Parts	C18	CU3004	C1608CH1H030CT-AS
Electrical Parts	C19	CU3035	C1608JB1H102KT-AS
Electrical Parts	C20	CU3020	C1608CH1H560JT-AS
Electrical Parts	C21	CU3015	C1608CH1H220JT-AS
Electrical Parts	C22	NC	
Electrical Parts	C23	CU3001	C1608CH1H0R5CT-AS
Electrical Parts	C24	CU3015	C1608CH1H220JT-AS
Electrical Parts	C25	CU3035	C1608JB1H102KT-AS
Electrical Parts	C26	CU3023	C1608CH1H101JT-AS
Electrical Parts	C27	CU3015	C1608CH1H220JT-AS
Electrical Parts	C28	CU3001	C1608CH1H0R5CT-AS
Electrical Parts	C29	CU3001	C1608CH1H0R5CT-AS
Electrical Parts	C30	CU3015	C1608CH1H220JT-AS
Electrical Parts	C31	CU3011	C1608CH1H100DT-AS
Electrical Parts	C32	CU3002	C1608CH1H010CT-AS
Electrical Parts	C33	CU3035	C1608JB1H102KT-AS
Electrical Parts	C34	CU3047	C1608JB1H103KT-N
Electrical Parts	C35	CU3035	C1608JB1H102KT-AS
Electrical Parts	C36	CU3035	C1608JB1H102KT-AS
Electrical Parts	C37	CU3035	C1608JB1H102KT-AS
Electrical Parts	C38	CU3001	C1608CH1H0R5CT-AS
Electrical Parts	C39	CU3001	C1608CH1H0R5CT-AS
Electrical Parts	C40	CU3011	C1608CH1H100DT-AS
Electrical Parts	C41	CU3035	C1608JB1H102KT-AS
Electrical Parts	C42	CU3035	C1608JB1H102KT-AS
Electrical Parts	C43	CU3023	C1608CH1H101JT-AS
Electrical Parts	C44	CU3035	C1608JB1H102KT-AS
Electrical Parts	C45	CU3035	C1608JB1H102KT-AS
Electrical Parts	C46	CU3035	C1608JB1H102KT-AS
Electrical Parts	C47	CU0108	LMK212BJ105KG
Electrical Parts	C48	CU3035	C1608JB1H102KT-AS
Electrical Parts	C49	CU3005	C1608CH1H040CT-AS
Electrical Parts	C50	NC	
Electrical Parts	C51	NC	
Electrical Parts	C52	NC	

Electrical Parts	C53	CU3035	C1608JB1H102KT-AS
Electrical Parts	C54	CU3047	C1608JB1H103KT-N
Electrical Parts	C55	CS0408	6MCM156MATER
Electrical Parts	C56	CU3019	C1608CH1H470JT-AS
Electrical Parts	C57	CU3007	C1608CH1H060CT-A
Electrical Parts	C58	CU3015	C1608CH1H220JT-AS
Electrical Parts	C59	CU3015	C1608CH1H220JT-AS
Electrical Parts	C60	CU3109	C1608CH1H110JT-A
Electrical Parts	C61	CU3014	C1608CH1H180JT-AS
Electrical Parts	C62	CU3007	C1608CH1H060CT-A
Electrical Parts	C63	NC	
Electrical Parts	C64	CU3047	C1608JB1H103KT-N
Electrical Parts	C65	CU3004	C1608CH1H030CT-AS
Electrical Parts	C66	CU3004	C1608CH1H030CT-AS
Electrical Parts	C68	CU3035	C1608JB1H102KT-AS
Electrical Parts	C69	CU3047	C1608JB1H103KT-N
Electrical Parts	C70	CS0063	TMCSA1V104MTR
Electrical Parts	C71	CU3001	C1608CH1H0R5CT-AS
Electrical Parts	C72	CU3035	C1608JB1H102KT-AS
Electrical Parts	C73	CU3047	C1608JB1H103KT-N
Electrical Parts	C74	CU3035	C1608JB1H102KT-AS
Electrical Parts	C75	CU3013	C1608CH1H150JT-AS
Electrical Parts	C76	CU3015	C1608CH1H220JT-AS
Electrical Parts	C77	CU3014	C1608CH1H180JT-AS
Electrical Parts	C78	CU3017	C1608CH1H330JT-AS
Electrical Parts	C79	CU3002	C1608CH1H010CT-AS
Electrical Parts	C80	CS0213	TMCMA1A225MTR
Electrical Parts	C81	CU3012	C1608CH1H120JT-AS
Electrical Parts	C82	CU0108	LMK212BJ105KG
Electrical Parts	C83	CU3035	C1608JB1H102KT-AS
Electrical Parts	C84	CU3035	C1608JB1H102KT-AS
Electrical Parts	C85	CU0108	LMK212BJ105KG
Electrical Parts	C86	CU3020	C1608CH1H560JT-AS
Electrical Parts	C87	CU3101	C1608JB1C473KT-NS
Electrical Parts	C88	CS0213	TMCMA1A225MTR
Electrical Parts	C89	CU3019	C1608CH1H470JT-AS
Electrical Parts	C90	CU0108	LMK212BJ105KG
Electrical Parts	C91	CU3035	C1608JB1H102KT-AS
Electrical Parts	C92	CU3035	C1608JB1H102KT-AS
Electrical Parts	C93	CE0392	6MV47UW
Electrical Parts	C94	CU3035	C1608JB1H102KT-AS
Electrical Parts	C95	CS0408	6MCM156MATER
Electrical Parts	C96	CU3035	C1608JB1H102KT-AS
Electrical Parts	C97	CU0108	LMK212BJ105KG
Electrical Parts	C98	CU3047	C1608JB1H103KT-N
Electrical Parts	C99	CS0408	6MCM156MATER
Electrical Parts	C100	CS0408	6MCM156MATER
Electrical Parts	C101	CU3047	C1608JB1H103KT-N
Electrical Parts	C102	CU3035	C1608JB1H102KT-AS
Electrical Parts	C103	CU0108	LMK212BJ105KG
Electrical Parts	C104	CU3035	C1608JB1H102KT-AS
Electrical Parts	C105	CS0404	6MCM106MATER
Electrical Parts	C106	CU3007	C1608CH1H060CT-A
Electrical Parts	C107	CS0408	6MCM156MATER

Electrical Parts	C108	CU3035	C1608JB1H102KT-AS
Electrical Parts	C109	CE0350	16MV100HC
Electrical Parts	C110	CU3035	C1608JB1H102KT-AS
Electrical Parts	C111	CE0397	MVS16VC47MF46
Electrical Parts	C112	CU0108	LMK212BJ105KG
Electrical Parts	C113	CU3047	C1608JB1H103KT-N
Electrical Parts	C114	CU3035	C1608JB1H102KT-AS
Electrical Parts	C115	CE0392	6MV47UW
Electrical Parts	C116	CU3111	C1608JB1C104KT-N
Electrical Parts	C117	CU3047	C1608JB1H103KT-N
Electrical Parts	C118	CS0408	6MCM156MATER
Electrical Parts	C119	CU3047	C1608JB1H103KT-N
Electrical Parts	C120	CU3035	C1608JB1H102KT-AS
Electrical Parts	C121	CS0408	6MCM156MATER
Electrical Parts	C122	CU3111	C1608JB1C104KT-N
Electrical Parts	C123	CU3111	C1608JB1C104KT-N
Electrical Parts	C124	CU3035	C1608JB1H102KT-AS
Electrical Parts	C125	CU3051	C1608JB1E223KT-NS
Electrical Parts	C126	CU3051	C1608JB1E223KT-NS
Electrical Parts	C127	CU3051	C1608JB1E223KT-NS
Electrical Parts	C128	CU3111	C1608JB1C104KT-N
Electrical Parts	C129	CU3111	C1608JB1C104KT-N
Electrical Parts	C130	CU0108	LMK212BJ105KG
Electrical Parts	C131	CU3111	C1608JB1C104KT-N
Electrical Parts	C132	CE0396	MVS6.3VC100MF46
Electrical Parts	C133	CS0408	6MCM156MATER
Electrical Parts	C134	CU3111	C1608JB1C104KT-N
Electrical Parts	C135	CU3035	C1608JB1H102KT-AS
Electrical Parts	C136	CU3035	C1608JB1H102KT-AS
Electrical Parts	C137	CU3101	C1608JB1C473KT-NS
Electrical Parts	C138	CU3111	C1608JB1C104KT-N
Electrical Parts	C139	CU0108	LMK212BJ105KG
Electrical Parts	C140	CU3035	C1608JB1H102KT-AS
Electrical Parts	C141	CU3035	C1608JB1H102KT-AS
Electrical Parts	C142	CU3047	C1608JB1H103KT-N
Electrical Parts	C143	CU3035	C1608JB1H102KT-AS
Electrical Parts	C144	CU3111	C1608JB1C104KT-N
Electrical Parts	C145	CU3025	C1608CH1H151JT-AS
Electrical Parts	C146	CU3041	C1608JB1H332KT-NS
Electrical Parts	C147	CU3035	C1608JB1H102KT-AS
Electrical Parts	C148	CU3111	C1608JB1C104KT-N
Electrical Parts	C149	CU3041	C1608JB1H332KT-NS
Electrical Parts	C150	CU3111	C1608JB1C104KT-N
Electrical Parts	C151	CU3111	C1608JB1C104KT-N
Electrical Parts	C152	CU3035	C1608JB1H102KT-AS
Electrical Parts	C153	CU3035	C1608JB1H102KT-AS
Electrical Parts	C154	CU3038	C1608JB1H182KT-AS
Electrical Parts	C155	CU3111	C1608JB1C104KT-N
Electrical Parts	C156	CU3035	C1608JB1H102KT-AS
Electrical Parts	C157	CU3050	C1608JB1E183KT-NS
Electrical Parts	C158	CU0108	LMK212BJ105KG
Electrical Parts	C159	CU3051	C1608JB1E223KT-NS
Electrical Parts	C160	CU0108	LMK212BJ105KG
Electrical Parts	C161	CS0408	6MCM156MATER

Electrical Parts	C162	CU3023	C1608CH1H101JT-AS
Electrical Parts	C163	CU3044	C1608JB1H562KT-NS
Electrical Parts	C164	CU3040	C1608JB1H272KT-NS
Electrical Parts	C165	CU3111	C1608JB1C104KT-N
Electrical Parts	C166	CU3047	C1608JB1H103KT-N
Electrical Parts	C167	CU3101	C1608JB1C473KT-NS
Electrical Parts	C168	CU3047	C1608JB1H103KT-N
Electrical Parts	C169	CU3047	C1608JB1H103KT-N
Electrical Parts	C170	CU3047	C1608JB1H103KT-N
Electrical Parts	C171	CU3046	C1608JB1H822KT-NS
Electrical Parts	C172	CU3035	C1608JB1H102KT-AS
Electrical Parts	C173	CU0108	LMK212BJ105KG
Electrical Parts	C174	CS0408	6MCM156MATER
Electrical Parts	C175	CU3111	C1608JB1C104KT-N
Electrical Parts	C176	CU3014	C1608CH1H180JT-AS
Electrical Parts	C177	CU3013	C1608CH1H150JT-AS
Electrical Parts	C178	CU0108	LMK212BJ105KG
Electrical Parts	C179	CU3035	C1608JB1H102KT-AS
Electrical Parts	C180	CU3111	C1608JB1C104KT-N
Electrical Parts	C181	CU3049	C1608JB1E153KT-NS
Electrical Parts	C182	CU3035	C1608JB1H102KT-AS
Electrical Parts	C183	CU3035	C1608JB1H102KT-AS
Electrical Parts	C184	NC	
Electrical Parts	C185	CU3111	C1608JB1C104KT-N
Electrical Parts	C186	CU3003	C1608CH1H020CT-AS
Electrical Parts	C187	CU3111	C1608JB1C104KT-N
Electrical Parts	C188	CS0398	TMCP0J225MTR
Electrical Parts	C189	CU3004	C1608CH1H030CT-AS
Electrical Parts	CN1	NC	
Electrical Parts	CN2	UE0369	AXN49301616
Electrical Parts	CN3	NC	
Electrical Parts	D1	XD0323	MA2S111-TX
Electrical Parts	D2	XD0331	HSU277TRF
Electrical Parts	D3	XD0316	MA2S376-TX
Electrical Parts	D4	XD0331	HSU277TRF
Electrical Parts	D5	XD0331	HSU277TRF
Electrical Parts	D7	XD0251	MA741WA TX
Electrical Parts	D8	XD0261	S3DG7
Electrical Parts	D9	XD0323	MA2S111-TX
Electrical Parts	D10	XD0130	DA204U T106
Electrical Parts	D11	XD0294	U2FWJ44N(TE12R)
Electrical Parts	D12	XD0316	MA2S376-TX
Electrical Parts	D13	XD0316	MA2S376-TX
Electrical Parts	D14	XD0316	MA2S376-TX
Electrical Parts	D15	XD0316	MA2S376-TX
Electrical Parts	D16	XD0131	1SV214 TPH4
Electrical Parts	D17	XL0036	SML-310MTT86
Electrical Parts	D18	XL0036	SML-310MTT86
Electrical Parts	D19	XL0028	BRPG1201W TR
Electrical Parts	D20	XL0036	SML-310MTT86
Electrical Parts	D21	XL0036	SML-310MTT86
Electrical Parts	D22	XL0036	SML-310MTT86
Electrical Parts	D23	XL0036	SML-310MTT86
Electrical Parts	D24	NC	

Electrical Parts	D25	XD0332	RB706F-40-T106
Electrical Parts	D26	XD0291	MA729-TX
Electrical Parts	D27	XD0342	1SS390 TE61
Electrical Parts	FL1	XC0072	ALFCM455F=K
Electrical Parts	IC1	XA0449	UPC2710T-E3
Electrical Parts	IC2	XA0915	M64076AGP
Electrical Parts	IC3	XA0888	XC6202P502PR
Electrical Parts	IC4	XA0515	TK14521MTL
Electrical Parts	IC5	XA0210	NJM2070M T1
Electrical Parts	IC6	XA0385	M5222FP-600C
Electrical Parts	IC7	XA0596	NJM2902V-TE1
Electrical Parts	IC8	XA0573	NJM2904V-TE1
Electrical Parts	IC9	XA0916	M38267M8L286GP
Electrical Parts	IC10	XA0669	BR24C64F-E2
Electrical Parts	IC11	XA0620	S-80845ALMP-EA9-T2
Electrical Parts	JK1	UJ0046	MJ82-1
Electrical Parts	JK2	UJ0019	HSJ1493-01-010
Electrical Parts	JK3	UJ0022	HSJ1102-01-540
Electrical Parts	L1	QC0507	LK16081R0K-T
Electrical Parts	L2	QKA45A	MR1.5 4.5T 0.4
Electrical Parts	L3	QKA65A	MR1.5 3.5T 0.4
Electrical Parts	L4	QC0507	LK16081R0K-T
Electrical Parts	L5	QKA45A	MR1.5 4.5T 0.4
Electrical Parts	L6	QKA35A	MR1.5 3.5T 0.4
Electrical Parts	L7	QC0563	LL1608-FH15NJ
Electrical Parts	L8	QC0533	LQN21A39NJ04
Electrical Parts	L9	QKA75A	QKA75A
Electrical Parts	L10	QC0573	LL1608-FHR10J
Electrical Parts	L11	QC0573	LL1608-FHR10J
Electrical Parts	L12	QC0531	LQN21A27NJ04
Electrical Parts	L13	QC0569	LL1608-FH47NJ
Electrical Parts	L14	QC0567	LL1608-FH33NJ
Electrical Parts	L15	NC	
Electrical Parts	L18	QC0508	LK16082R2K-T
Electrical Parts	L19	QC0568	LL1608-FH39NJ
Electrical Parts	L20	QC0535	LQN21A56NJ04
Electrical Parts	L21	QC0535	LQN21A56NJ04
Electrical Parts	L22	QC0567	LL1608-FH33NJ
Electrical Parts	L23	NC	
Electrical Parts	L24	QC0573	LL1608-FHR10J
Electrical Parts	L25	QC0540	LQN21AR15J04
Electrical Parts	L26	QC0089	NL322522T-181JA
Electrical Parts	L28	QC0570	LL1608-FH56NJ
Electrical Parts	LCD1	EL0044	HT-3404
Electrical Parts	MIC1	EY0017	OB-27P44
Electrical Parts	Q1	XT0135	2SD2216R-TX
Electrical Parts	Q2	XE0038	2SK2975-T11-A
Electrical Parts	Q3	XT0138	2SC5066-O(TE85L)
Electrical Parts	Q4	XE0034	MRF9745T1
Electrical Parts	Q5	XT0138	2SC5066-O(TE85L)
Electrical Parts	Q6	XU0172	XP1501-TX
Electrical Parts	Q7	XT0170	2SB766A-TX
Electrical Parts	Q8	XT0172	2SC4618TLP
Electrical Parts	Q9	XT0138	2SC5066-O(TE85L)

Electrical Parts	Q10	XT0171	2SC4808-TX.AR
Electrical Parts	Q11	XT0171	2SC4808-TX.AR
Electrical Parts	Q12	XU0193	RN1107 TE85L
Electrical Parts	Q13	XT0170	2SB766A-TX
Electrical Parts	Q14	XT0170	2SB766A-TX
Electrical Parts	Q15	XU0193	RN1107 TE85L
Electrical Parts	Q16	XU0172	XP1501-TX
Electrical Parts	Q17	XT0110	2SA1036K T146Q
Electrical Parts	Q18	XU0193	RN1107 TE85L
Electrical Parts	Q19	XU0197	RN1111 (TE85L)
Electrical Parts	Q20	XU0172	XP1501-TX
Electrical Parts	Q21	XU0161	XP1114(TX)
Electrical Parts	Q22	XU0192	RN2107 TE85L
Electrical Parts	Q23	XT0135	2SD2216R-TX
Electrical Parts	Q24	XU0197	RN1111 (TE85L)
Electrical Parts	Q25	XU0197	RN1111 (TE85L)
Electrical Parts	Q26	XU0193	RN1107 TE85L
Electrical Parts	Q27	XT0095	2SC4081 T106R
Electrical Parts	Q28	XU0192	RN2107 TE85L
Electrical Parts	Q29	XU0092	UN911H-TX
Electrical Parts	Q30	XU0195	RN1104 TE85L
Electrical Parts	Q31	XT0135	2SD2216R-TX
Electrical Parts	Q32	XE0029	2SK1580-T1
Electrical Parts	Q33	XT0135	2SD2216R-TX
Electrical Parts	Q34	XE0029	2SK1580-T1
Electrical Parts	Q35	XU0194	RN2111 TE85L
Electrical Parts	Q36	XU0197	RN1111 (TE85L)
Electrical Parts	Q37	XT0171	2SC4808-TX.AR
Electrical Parts	R1	RK3030	MCR03EZHZ221
Electrical Parts	R2	RK3034	MCR03EZHZ471
Electrical Parts	R3	RK3046	MCR03EZHZ472
Electrical Parts	R4	RK3050	MCR03EZHZ103
Electrical Parts	R5	RK3030	MCR03EZHZ221
Electrical Parts	R6	RK3067	MCR03EZHZ274
Electrical Parts	R7	RK3018	MCR03EZHZ220
Electrical Parts	R8	RK3048	MCR03EZHZ682
Electrical Parts	R9	RK3020	MCR03EZHZ330
Electrical Parts	R10	RK3018	MCR03EZHZ220
Electrical Parts	R11	RK3050	MCR03EZHZ103
Electrical Parts	R12	RK3063	MCR03EZHZ124
Electrical Parts	R13	RK3034	MCR03EZHZ471
Electrical Parts	R14	RK3026	MCR03EZHZ101
Electrical Parts	R16	RK3062	MCR03EZHZ104
Electrical Parts	R18	RK3050	MCR03EZHZ103
Electrical Parts	R19	RK3062	MCR03EZHZ104
Electrical Parts	R20	RK3062	MCR03EZHZ104
Electrical Parts	R21	RK3062	MCR03EZHZ104
Electrical Parts	R22	RK3056	MCR03EZHZ333
Electrical Parts	R23	RK3052	MCR03EZHZ153
Electrical Parts	R24	RK3058	MCR03EZHZ473
Electrical Parts	R25	RK0002	ERJ6GEYJ120V
Electrical Parts	R26	RK3050	MCR03EZHZ103
Electrical Parts	R27	RK3034	MCR03EZHZ471
Electrical Parts	R28	RK3042	MCR03EZHZ222

Electrical Parts	R29	RK3051	MCR03EZHZ123
Electrical Parts	R30	RK3051	MCR03EZHZ123
Electrical Parts	R31	RK3026	MCR03EZHZ101
Electrical Parts	R33	RK3050	MCR03EZHZ103
Electrical Parts	R34	RK3062	MCR03EZHZ104
Electrical Parts	R35	RK3035	MCR03EZHZ561
Electrical Parts	R36	RK3066	MCR03EZHZ224
Electrical Parts	R37	RK3050	MCR03EZHZ103
Electrical Parts	R38	RK3046	MCR03EZHZ472
Electrical Parts	R39	RK3062	MCR03EZHZ104
Electrical Parts	R40	RK3063	MCR03EZHZ124
Electrical Parts	R41	RK3036	MCR03EZHZ681
Electrical Parts	R42	RK3038	MCR03EZHZ102
Electrical Parts	R43	RK3050	MCR03EZHZ103
Electrical Parts	R44	RK3047	MCR03EZHZ562
Electrical Parts	R45	RK3050	MCR03EZHZ103
Electrical Parts	R46	RK3030	MCR03EZHZ221
Electrical Parts	R47	RK3030	MCR03EZHZ221
Electrical Parts	R48	RK3049	MCR03EZHZ822
Electrical Parts	R49	RK3066	MCR03EZHZ224
Electrical Parts	R50	RK3038	MCR03EZHZ102
Electrical Parts	R51	RK3026	MCR03EZHZ101
Electrical Parts	R52	RK3074	MCR03EZHZ105
Electrical Parts	R53	RK3074	MCR03EZHZ105
Electrical Parts	R54	RK3074	MCR03EZHZ105
Electrical Parts	R55	RK3074	MCR03EZHZ105
Electrical Parts	R57	RK3030	MCR03EZHZ221
Electrical Parts	R58	RK3074	MCR03EZHZ105
Electrical Parts	R59	RK3064	MCR03EZHZ154
Electrical Parts	R60	RK3058	MCR03EZHZ473
Electrical Parts	R61	RK3050	MCR03EZHZ103
Electrical Parts	R62	RK3058	MCR03EZHZ473
Electrical Parts	R63	NC	
Electrical Parts	R64	RK3050	MCR03EZHZ103
Electrical Parts	R65	RK3058	MCR03EZHZ473
Electrical Parts	R66	RK3054	MCR03EZHZ223
Electrical Parts	R67	RK3076	MCR03EZHZ155
Electrical Parts	R68	RK3076	MCR03EZHZ155
Electrical Parts	R69	RK3058	MCR03EZHZ473
Electrical Parts	R70	RK3058	MCR03EZHZ473
Electrical Parts	R71	RK3042	MCR03EZHZ222
Electrical Parts	R72	RK3058	MCR03EZHZ473
Electrical Parts	R73	RK3036	MCR03EZHZ681
Electrical Parts	R74	RK3050	MCR03EZHZ103
Electrical Parts	R75	RK3058	MCR03EZHZ473
Electrical Parts	R76	RK3054	MCR03EZHZ223
Electrical Parts	R77	RK3050	MCR03EZHZ103
Electrical Parts	R78	RK3054	MCR03EZHZ223
Electrical Parts	R79	RK3022	MCR03EZHZ470
Electrical Parts	R80	RK3062	MCR03EZHZ104
Electrical Parts	R81	RK3042	MCR03EZHZ222
Electrical Parts	R82	RK3046	MCR03EZHZ472
Electrical Parts	R83	RK3050	MCR03EZHZ103
Electrical Parts	R84	RK3036	MCR03EZHZ681

Electrical Parts	R85	RK3050	MCR03EZHJ103
Electrical Parts	R86	RK3038	MCR03EZHJ102
Electrical Parts	R87	RK3050	MCR03EZHJ103
Electrical Parts	R88	NC	
Electrical Parts	R89	RK3001	MCR03EZHJ000
Electrical Parts	R90	RK3032	MCR03EZHJ331
Electrical Parts	R91	RK3062	MCR03EZHJ104
Electrical Parts	R92	RK3058	MCR03EZHJ473
Electrical Parts	R93	RK3050	MCR03EZHJ103
Electrical Parts	R94	RK3050	MCR03EZHJ103
Electrical Parts	R95	RK3036	MCR03EZHJ681
Electrical Parts	R96	RK3032	MCR03EZHJ331
Electrical Parts	R97	RK3058	MCR03EZHJ473
Electrical Parts	R98	RK3044	MCR03EZHJ332
Electrical Parts	R99	RK3050	MCR03EZHJ103
Electrical Parts	R100	NC	
Electrical Parts	R101	RK3036	MCR03EZHJ681
Electrical Parts	R102	RK3062	MCR03EZHJ104
Electrical Parts	R103	RK3050	MCR03EZHJ103
Electrical Parts	R104	RK3050	MCR03EZHJ103
Electrical Parts	R105	RK3041	MCR03EZHJ182
Electrical Parts	R106	RK3052	MCR03EZHJ153
Electrical Parts	R107	RK3048	MCR03EZHJ682
Electrical Parts	R108	RK3052	MCR03EZHJ153
Electrical Parts	R109	RK3050	MCR03EZHJ103
Electrical Parts	R110	RK3050	MCR03EZHJ103
Electrical Parts	R111	RK3066	MCR03EZHJ224
Electrical Parts	R112	RK3054	MCR03EZHJ223
Electrical Parts	R113	RK3050	MCR03EZHJ103
Electrical Parts	R114	RK3038	MCR03EZHJ102
Electrical Parts	R115	RK3062	MCR03EZHJ104
Electrical Parts	R116	RK3066	MCR03EZHJ224
Electrical Parts	R117	RK3074	MCR03EZHJ105
Electrical Parts	R118	RK3014	MCR03EZHJ100
Electrical Parts	R119	RK3051	MCR03EZHJ123
Electrical Parts	R120	RK3042	MCR03EZHJ222
Electrical Parts	R121	NC	
Electrical Parts	R122	RK3032	MCR03EZHJ331
Electrical Parts	R123	RK3062	MCR03EZHJ104
Electrical Parts	R124	RK3070	MCR03EZHJ474
Electrical Parts	R125	RK1018	ERJ8GEYJ101V
Electrical Parts	R126	RK3058	MCR03EZHJ473
Electrical Parts	R127	RK3062	MCR03EZHJ104
Electrical Parts	R128	RK3062	MCR03EZHJ104
Electrical Parts	R129	RK3055	MCR03EZHJ273
Electrical Parts	R130	RK3062	MCR03EZHJ104
Electrical Parts	R131	RK3050	MCR03EZHJ103
Electrical Parts	R132	RK3046	MCR03EZHJ472
Electrical Parts	R133	RK3046	MCR03EZHJ472
Electrical Parts	R134	RK3046	MCR03EZHJ472
Electrical Parts	R135	RK3046	MCR03EZHJ472
Electrical Parts	R136	RK3074	MCR03EZHJ105
Electrical Parts	R137	RK3050	MCR03EZHJ103
Electrical Parts	R138	RK3022	MCR03EZHJ470

Electrical Parts	R139	RK3057	MCR03EZHZ393
Electrical Parts	R140	RK3058	MCR03EZHZ473
Electrical Parts	R141	RK3054	MCR03EZHZ223
Electrical Parts	R142	RK3042	MCR03EZHZ222
Electrical Parts	R143	RK3058	MCR03EZHZ473
Electrical Parts	R144	RK3061	MCR03EZHZ823
Electrical Parts	R145	RK3050	MCR03EZHZ103
Electrical Parts	R146	RK3058	MCR03EZHZ473
Electrical Parts	R147	RK3045	MCR03EZHZ392
Electrical Parts	R148	RK3063	MCR03EZHZ124
Electrical Parts	R149	RK3040	MCR03EZHZ152
Electrical Parts	R150	RK3038	MCR03EZHZ102
Electrical Parts	R151	RK3038	MCR03EZHZ102
Electrical Parts	R152	RK3062	MCR03EZHZ104
Electrical Parts	R153	RK3065	MCR03EZHZ184
Electrical Parts	R154	RK3061	MCR03EZHZ823
Electrical Parts	R155	RK3057	MCR03EZHZ393
Electrical Parts	R156	RK3049	MCR03EZHZ822
Electrical Parts	R157	RK3059	MCR03EZHZ563
Electrical Parts	R158	RK3063	MCR03EZHZ124
Electrical Parts	R159	RK3052	MCR03EZHZ153
Electrical Parts	R160	RK3068	MCR03EZHZ334
Electrical Parts	R161	RK3045	MCR03EZHZ392
Electrical Parts	R162	RK3062	MCR03EZHZ104
Electrical Parts	R163	RK3048	MCR03EZHZ682
Electrical Parts	R164	RK3038	MCR03EZHZ102
Electrical Parts	R165	RK3050	MCR03EZHZ103
Electrical Parts	R166	RK3074	MCR03EZHZ105
Electrical Parts	R167	RK3038	MCR03EZHZ102
Electrical Parts	R168	RK3046	MCR03EZHZ472
Electrical Parts	R169	RK3066	MCR03EZHZ224
Electrical Parts	R170	RK3069	MCR03EZHZ394
Electrical Parts	R171	RK3072	MCR03EZHZ684
Electrical Parts	R172	RK3050	MCR03EZHZ103
Electrical Parts	R173	RK3050	MCR03EZHZ103
Electrical Parts	R174	RK3050	MCR03EZHZ103
Electrical Parts	R175	RK3038	MCR03EZHZ102
Electrical Parts	R176	RK3060	MCR03EZHZ683
Electrical Parts	R177	RK3067	MCR03EZHZ274
Electrical Parts	R178	RK3050	MCR03EZHZ103
Electrical Parts	R179	RK3060	MCR03EZHZ683
Electrical Parts	R180	RK3055	MCR03EZHZ273
Electrical Parts	R181	RK3062	MCR03EZHZ104
Electrical Parts	R182	RK3050	MCR03EZHZ103
Electrical Parts	R183	RK3051	MCR03EZHZ123
Electrical Parts	R184	RK3063	MCR03EZHZ124
Electrical Parts	R185	RK3048	MCR03EZHZ682
Electrical Parts	R186	RK3038	MCR03EZHZ102
Electrical Parts	R187	RK3046	MCR03EZHZ472
Electrical Parts	R188	RK3038	MCR03EZHZ102
Electrical Parts	R189	RK3046	MCR03EZHZ472
Electrical Parts	R190	RK3050	MCR03EZHZ103
Electrical Parts	R191	RK3050	MCR03EZHZ103
Electrical Parts	R192	RK3066	MCR03EZHZ224

Electrical Parts	R193	RK3066	MCR03EZHZ224
Electrical Parts	R194	RK3074	MCR03EZHZ105
Electrical Parts	R195	NC	
Electrical Parts	R196	RK3062	MCR03EZHZ104
Electrical Parts	R197	RK3062	MCR03EZHZ104
Electrical Parts	R198	RK3001	MCR03EZHZ000
Electrical Parts	R199	RK3066	MCR03EZHZ224
Electrical Parts	R200	RK3066	MCR03EZHZ224
Electrical Parts	R201	RK3074	MCR03EZHZ105
Electrical Parts	R202	RK3062	MCR03EZHZ104
Electrical Parts	R203	RK3062	MCR03EZHZ104
Electrical Parts	R204	RK3062	MCR03EZHZ104
Electrical Parts	R205	RK3066	MCR03EZHZ224
Electrical Parts	R206	RK3074	MCR03EZHZ105
Electrical Parts	R207	RK3074	MCR03EZHZ105
Electrical Parts	R208	RK3058	MCR03EZHZ473
Electrical Parts	R209	RK3065	MCR03EZHZ184
Electrical Parts	R210	NC	
Electrical Parts	R211	NC	
Electrical Parts	R212	NC	
Electrical Parts	R213	NC	
Electrical Parts	R214	RK3046	MCR03EZHZ472
Electrical Parts	R215	NC	
Electrical Parts	R216	RK3062	MCR03EZHZ104
Electrical Parts	R217	RK3043	MCR03EZHZ272
Electrical Parts	R218	RK0107	ERJ6GEY0R00V
Electrical Parts	R219	RK3058	MCR03EZHZ473
Electrical Parts	R220	RK3066	MCR03EZHZ224
Electrical Parts	R221	RK3030	MCR03EZHZ221
Electrical Parts	R222	RK3030	MCR03EZHZ221
Electrical Parts	R223	NC	
Electrical Parts	R224	RK3062	MCR03EZHZ104
Electrical Parts	R225	NC	
Electrical Parts	R226	RK3001	MCR03EZHZ000
Electrical Parts	R227	RK3042	MCR03EZHZ222
Electrical Parts	R228	RK3001	MCR03EZHZ000
Electrical Parts	R229	NC	
Electrical Parts	R230	NC	
Electrical Parts	R231	RK3001	MCR03EZHZ000
Electrical Parts	R232	RK3050	MCR03EZHZ103
Electrical Parts	R233	RK3042	MCR03EZHZ222
Electrical Parts	SW17	UU0030	EVQPJ005Q
Electrical Parts	SW18	UU0030	EVQPJ005Q
Electrical Parts	TC1	CT0046	TC03C100A-TP02
Electrical Parts	VR1	RH0142	MVR22HXBRN103
Electrical Parts	VR2	RH0146	MVR22HXBRN473
Electrical Parts	VR3	RH0140	MVR22HXBRN472
Electrical Parts	W1	MACL07AA	#30A02-070-02
Electrical Parts	W2	MACL07AA	#30A02-070-02
Electrical Parts	W3	MACLH2GG	#30AH1-025-H1
Electrical Parts	X1	XQ0096	12.8MHZ 5PPM UM5
Electrical Parts	X2	XQ0058A	UM-5 30.395MHZ
Electrical Parts	X3	XQ0131	CSA310 3.686400MHZ
Electrical Parts	XF1	XF0055	UM-5-3P 30.85MHZ

Electrical Parts		UP0404A	DJ496 INTEGRATED
Mechanical Parts	RE1	UR0019	RH70N00E20 (RY-6320)
Mechanical Parts		AF0012	0PH M2+4 FE/ZN3
Mechanical Parts		AF0020Z	1P 2X3 NIC
Mechanical Parts		AF0029	XQN2+C9FN
Mechanical Parts		AK0001Z	BT 3P 2X4 NIC
Mechanical Parts		AN0012	RND N7X0.75 BR/B.ZN
Mechanical Parts		AN0025	RND N3/8-32BR/N
Mechanical Parts		DG0035	LCD LIGHT
Mechanical Parts		DP0146	LCD PANEL DJ296
Mechanical Parts		ES0024	36-8BB-21
Mechanical Parts		FF0029	CLOTH 4.0X22
Mechanical Parts		FG0274	DC CAP
Mechanical Parts		FG0286	KL6766-JACK CAPDJ195
Mechanical Parts		FG0289	TERMINAL RUBBER 195
Mechanical Parts		FG0290	KL6767-PTT DJ195
Mechanical Parts		FG0291	LCD RUBBER CONNECT.
Mechanical Parts		FG0304	KL3735-3 16KEY DJ196
Mechanical Parts		FG0324	LCD CUSHION DJ496
Mechanical Parts		FM0176	PLUS TERMINAL DJ195
Mechanical Parts		FM0177	RADIATIVE PLATE 195
Mechanical Parts		FM0178	PIN DJ195
Mechanical Parts		FM0179	Antenna Earth DJ195
Mechanical Parts		FM0187	REAR PANEL DJ196
Mechanical Parts		KZ0098	Front Case DJ195
Mechanical Parts		NK0068	DIAL KNOB DJ195
Mechanical Parts		RD0108	J1/6Z
Mechanical Parts		SS0092A	CHASSIS DJ196
Mechanical Parts		ST0063	LCD HOLDER DJ195
Mechanical Parts		TL0022	REFLECTIVE SHEET 195
Mechanical Parts		TS0142	VCO Case XH655
Mechanical Parts		TS0148	VCO Shield DJP85
Mechanical Parts		TW0020	W.PROOF A XH720
Mechanical Parts		TZ0049	SILICON DUMPER
Mechanical Parts		UE0441	ANT. CONNECT
Mechanical Parts		YX0024	LCD TAPE DJ195
Packing Parts		BB0009Y	Strap
Packing Parts		DS0446	Spec. sheet
Packing Parts		EA0079	Antenna
Packing Parts		EBP50N	Ni-MH Battery Pack
Packing Parts		EDC17	Belt Clip
Packing Parts		EDC93	Wall Charger 120V
Packing Parts		HH0061	Air cap
Packing Parts		HK0550	Package
Packing Parts		HM0211	Carton
Packing Parts		HU0150	Inner C
Packing Parts		HU0174	Inner 10
Packing Parts		PH0013	Warranty
Packing Parts		PK0093	Schematic Diagram
Packing Parts		PR0433	A level
Packing Parts		PR0447	FCC warning level
Packing Parts		PR0452	FCC home use level
Packing Parts		PS0358C	Instruction Manual

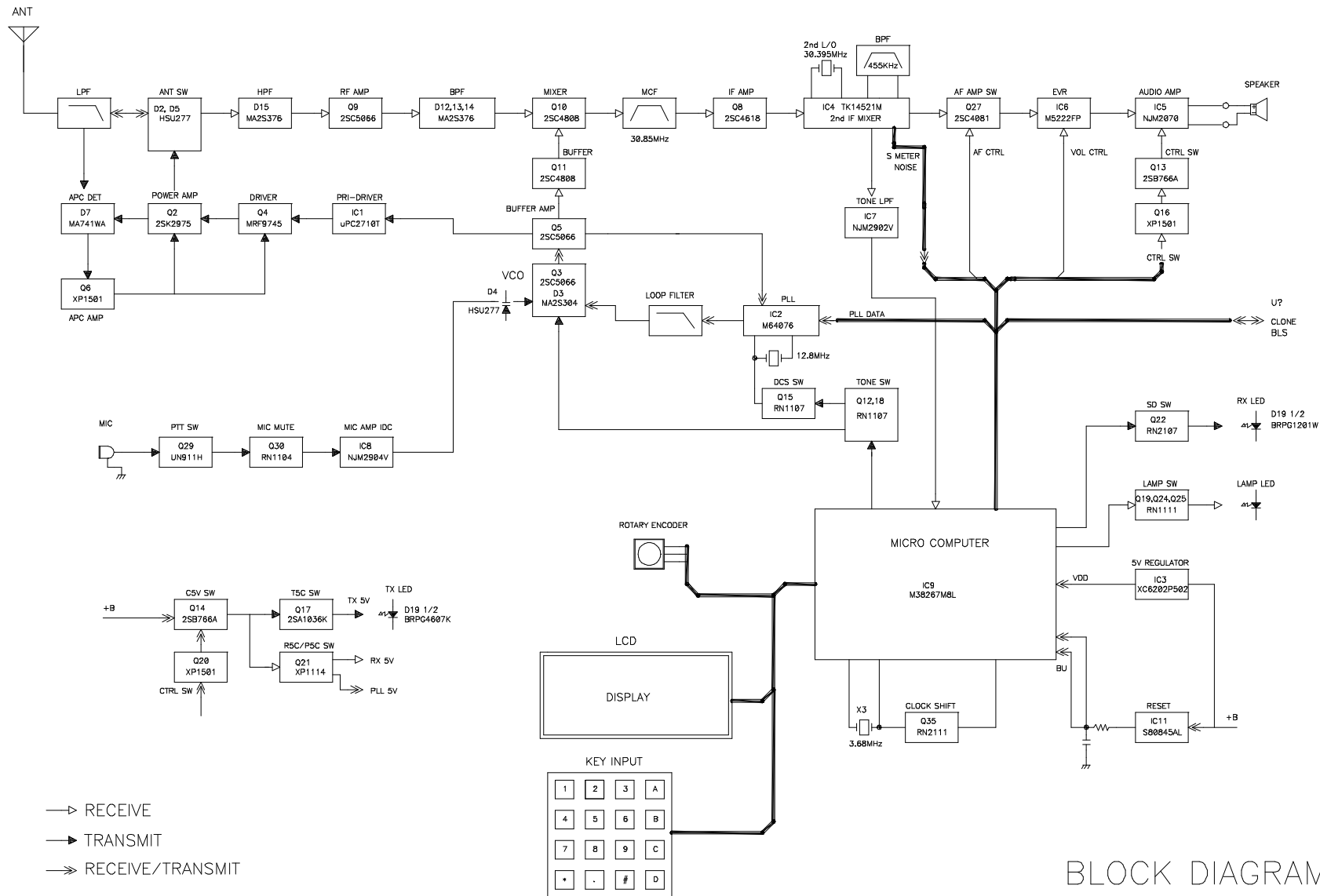

de-emphasis circuit (R106, R107, C127 and C128) and amplified by the AF amplifier (Q27). The signal is then input to pin 2 of the electronic volume (IC6) for volume adjustment, and output from pin 1. The adjusted signal is sent to the audio power amplifier (IC5) through pin 2 to drive the speaker.

2) Transmitter System

1. Modulator Circuit

The audio signal is converted to an electric signal in either the internal or external microphone, and input to the microphone amplifier (IC8). IC8 consists of two operational amplifiers; one amplifier (pins 5, 6 and 7) is composed of pre-emphasis and IDC circuits and the other (pins 1, 2, and 3) is composed of a splatter filter. The maximum frequency deviation is obtained by VR1 and input to the cathode of the varicap (D3) of the VCO, to change the electric capacity in the oscillation circuit. This produces the frequency modulation.

2. Power Amplifier Circuit

The transmitted signal is oscillated by the VCO, amplified by the pre-drive IC (IC1) and drive amplifier (Q4), and input to the final amplifier (Q2). The signal is then amplified by the final amplifier (Q2) and led to the antenna switch (D2 and D5) and low-pass filter (L2, L3, L5, C2, C9, C10, C11, C24, and C189), where unwanted high harmonic waves are reduced as needed, and the resulting signal is supplied to the antenna.

3. APC Circuit

Part of the transmission power from the low-pass filter is detected by D7, converted to DC, and then amplified by a differential amplifier. The output voltage controls the bias voltage from the source of Q2 and Q4 to maintain the transmission power constant.

3) PLL Synthesizer Circuit

1. PLL

The dividing ratio is obtained by sending data from the CPU (IC9) to pin 2 and sending clock pulses to pin 3 of the PLL IC (IC2). The oscillated signal from the VCO is amplified by the buffer (Q5 and Q37) and input to pin 6 of IC2. Each programmable divider in IC2 divides the frequency of the input signal by N according to the frequency data, to generate a comparison

frequency of 5 or 6.25 kHz.

2. Reference Frequency Circuit

The reference frequency appropriate for the channel steps is obtained by dividing the 12.8 MHz reference oscillation (X1) by 2048 or 2560, according to the data from the CPU (IC9). When the resulting frequency is 5 kHz, channel steps of 5, 10, 15, 20, 25, 30 and 50 kHz are used. When it is 6.25 kHz, the 12.5 kHz channel step is used.

3. Phase Comparator Circuit

The PLL (IC1) uses the reference frequency, 5 or 6.25kHz. The phase comparator in the IC2 compares the phase of the frequency from the VCO with that of the comparison frequency, 5 or 6.25kHz, which is obtained by the internal divider in IC2.

4. PLL Loop Filter Circuit

If a phase difference is found in the phase comparison between the reference frequency and VCO output frequency, the charge pump output (pin 8) of IC1 generates a pulse signal, which is converted to DC voltage by the PLL loop filter (C69, C70, C80, C88, R44 and R48) and input to the varicap (D3) of the VCO unit for oscillation frequency control.

5. VCO Circuit A Colpitts oscillation circuit driven by Q3 directly oscillates the desired frequency. The frequency control voltage determined in the CPU (IC9) and PLL circuit is input to the varicaps (D3). This change the oscillation frequency, which is amplified by the VCO buffer (Q5) and output from the VCO unit.

4) CPU and Peripheral Circuits

1. LCD Display Circuit

The CPU turns ON the LCD via segment and common terminals with 1/4 the duty and 1/4 the bias, at the frame frequency is 112.5Hz.

2. Display Lamp and Key Lamp Circuit

When the LAMP key is pressed, "H" is output form pin 42 of the CPU (IC9) to the bases of Q19, Q24 and Q25. Q19, Q24 and Q25 then turn ON and the LED's (D17, D18, D20, D21, D22 and D23) light.

3. Reset and Backup

When the power form the DC jack or external battery increases from Circuits 0 V to 2.5 or more,

“H” level reset signal is output from the reset IC (IC11) to pin 33 of the CPU (IC9), causing the CPU to reset. The reset signal, however, waits at 100, and does not enter the CPU until the CPU clock (X3) has stabilized.

4. S (Signal) Meter Circuit

The DC potential of pin 8 of IC5 is input to pin 1 of the CPU (IC9), converted from an analog to a digital signal, and displayed as the S-meter signal on the LCD.

5. DTMF Encoder

The CPU (IC9) is equipped with an internal DTMF encoder. The DTMF signal is output from pin 10, through R179 and R180 (for level adjustment), and then through the microphone amplifier (IC8), and is sent to the varicap of the VCO for modulation. At the same time, the monitoring tone passes through the AF circuit and is output from the speaker.

6. CTCSS Encoder

The CPU (IC9) is equipped with an internal tone encoder. The tone signal (67.0 to 250.3 Hz) is output from pin 9 of the CPU to the varicap D4 of the VCO for modulation.