

**ALINCO**

VHF FM HANDHELD TRANSCEIVER

**DJ-180B**

**User's Manual**

[www.r6-ru4monteseccchieta.it](http://www.r6-ru4monteseccchieta.it)

IZ5CCV

**ALINCO, INC.**

Head office: TWIN 21\* MID Tower Building 25F  
1-61, 2-Chome, Shiromi, Chuo-Ku, Osaka 540-8560 Japan  
Phone: 06-946-8150 Fax: 06-946-8175 Telex: 63086  
E-mail: 101243.1446@compuserve.com  
U.S.A.: 438 Amapola Ave., Suite 130, Torrance, CA 90501-6201 U.S.A.  
Phone: 310-618-8616 Fax: 310-618-8758  
<http://www.alinco.com>  
Germany: Eschborner Landstrasse 55, 60489 Frankfurt am Main, Germany  
Phone: 069-786018 Fax: 069-789-60766

# TABLE OF CONTENTS

INTRODUCTION .....	1
<b>1. ACCESSORIES</b> .....	1
Optional Accessories .....	1
<b>2. SPECIFICATIONS</b> .....	2
2-1 General .....	2
2-2 Transmitter .....	2
2-3 Receiver .....	2
<b>3. PANEL DESCRIPTION</b> .....	3
3-1 Front, Top and Side View .....	3
3-2 LCD .....	6
<b>4. BASIC OPERATION</b> .....	8
4-1 Receiving .....	8
4-2 Transmitting .....	8
<b>5. PRACTICAL OPERATION</b> .....	9
5-1 Scanning .....	9
5-2 Monitor Function .....	10
5-3 Lamp Function .....	10
5-4 Low Battery Indicator .....	10
5-5 Key Lock Function .....	10
5-6 Selecting Output Power .....	10
5-7 Simplex Phonepatch .....	11
5-8 Battery Save Function .....	11
5-9 Bank Selection .....	11
5-10 APO (Auto-Power-Off) Setting .....	12
5-11 Squelch H/L .....	12
5-12 Channel Selection by Direct Key .....	12
<b>6. SELECTIVE CALLING</b> .....	13
6-1 Tone Squelch .....	13
6-2 DTMF Squelch .....	14
6-2-1 3-Digit Paper Mode .....	14
6-2-2 7-Digit Paper Mode .....	16
6-2-3 DTMF Cancel Mode .....	20
6-2-4 Auto-Dial .....	21
6-2-5 Auto-redial .....	22
6-3 DTMF and Tone Squelch (squelch system) .....	22
6-4 Time-Out Timer/Penalty .....	24

## NOTICE

This equipment has been tested and found to comply with the limits pursuant to Part 15 of the FCC Rules. These limits are designed to provide reasonable protection against harmful interference in a residential installation. This equipment generates, uses, and can radiate radio frequency energy, and if not installed and used in accordance with the instructions, may cause harmful interference to radio communications. However, there is no guarantee that interference will not occur in a particular installation. If this equipment does cause harmful interference to radio or television reception, which can be determined by turning the equipment off and on, the user is encouraged to try to correct the interference by one or more of the following measures.

- *Reorient to relocate the receiving antenna.*
- *Increase the separation between the equipment and receiver.*
- *Connect the equipment into an outlet on a circuit different from that which the receiver is connected.*
- *Consult the dealer or an experienced radio/TV technician for help.*

Information in this document are subject to change without notice or obligation. All brand names and trademarks are the property of their respective owners. Alinco cannot be liable for pictorial or typographical inaccuracies. Some options and/or accessories are unavailable in certain areas.

©Copyright 1998 All rights reserved. No part of this document may be reproduced, copied, translated or transcribed in any form or by any means without the prior written permission of Alinco, Inc., Osaka, Japan. English Edition Printed in Japan/Édition Anglaise Imprimé au Japon.

# INTRODUCTION

Thank you for purchasing the "ALINCO" transmitter.

ALINCO radios and other products are ranked as some of the finest in the world. Your transmitter has been manufactured and tested very carefully at the factory and will give you satisfactory operation for many years. We are confident that you will be very satisfied with your choice of this fine ALINCO radio.

# 1. ACCESSORIES

## OPTIONAL ACCESSORIES

- Ni-Cd Battery Pack 7.2V 700mAh..... EBP-26N
- Ni-Cd Battery Pack 12V 700mAh..... EBP-28N
- Ni-Cd Long life Battery Pack 7.2V 1200mAh..... EBP-24N
- Dry Cell Case (1.5V x 6 pcs.)..... EDH-11
- A.C. Wall Charger..... EDC-83 (for 117V A.C.)
- A.C. Wall Charger..... EDC-84 (for 220/240V A.C.)
- A.C. Drop-in Charger..... EDC-49 (for 117V A.C.)
- A.C. Drop-in Charger..... EDC-50 (for 220/240V A.C.)
- A.C. Quick Charger..... EDC-45 (for 117V A.C.)
- A.C. Quick Charger..... EDC-46 (for 220/240V A.C.)
- Speaker microphone..... EMS-9
- Mobile bracket..... EBC-6
- Headset (ear hook)..... EME-12
- Headset (inner)..... EME-13
- Tie-Pin microphone..... EME-15
- Soft Case (standard size)..... ESC-18
- Soft Case (big size)..... ESC-19
- Tone Squelch Unit..... EJ-17U
- ALTrunk Logic Board (digital)..... EJ-18D

# 2. SPECIFICATIONS

## 2-1 GENERAL

- Frequency Coverage..... 136.000~155.000MHz (DJ-180B1)  
150.000~173.995MHz (DJ-180B2)
- Tuning Step..... 5, 10, 12.5, 15, 20, 25 kHz steps
- Memory Channels..... 40 channels x 4 banks
- Antenna Impedance..... 50Ω unbalanced
- Modulation..... F3E (FM)
- Power Supply Requirement..... 5.5~13.8 VDC (Standard: 7.2 VDC)
- Dimensions..... Approx. 132 (H) x 58 (W) x 33 (D) mm  
Approx. 5.2" (H) x 2.3" (W) x 1.3" (D)
- Weight..... Approx. 350g

## 2-2 TRANSMITTER

- Output Power..... About 2.0W with Ni-Cd Battery Pack EBP-26N  
About 5.0W with Ni-Cd Battery Pack EBP-28N
- Modulation System..... Variable reactance frequency modulation
- Max. Freq. Deviation..... ± 5 kHz
- Tone Frequency..... 67.0 to 250.3 Hz 38 Subaudible encoding tones (option EJ-17U)
- TX/RX Offset Range..... 0~±99.995 MHz

## 2-3 RECEIVER

- Receiving System..... Double-conversion superheterodyne
- Intermediate Frequency..... 1st: 21.4 MHz 2nd: 455 kHz
- Sensitivity..... 12 dB SINAD less than -16 dBμ
- Selectivity..... less than at ±12 kHz/-6 dB

NOTE: Specifications are subject to change without notice.

### 3. PANEL DESCRIPTION

#### 3-1 FRONT, TOP AND SIDE VIEW

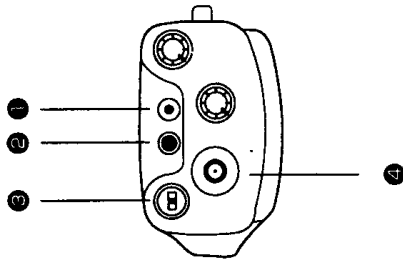

- ① **MIC connector**  
Connects optional earphone microphone, speaker microphone, or headsets. (Not to be used when EJ-18D is installed)
- ② **SP connector**  
Connects an optional speaker.
- ③ **Antenna connector**  
Connects the supplied antenna. An external antenna can be connected with a BNC connector.
- ④ **Charger terminal**  
For connecting the charger EDC-84 (230VAC) or EDC-83 (120VAC). Do not connect anything here when using the drycell battery pack.

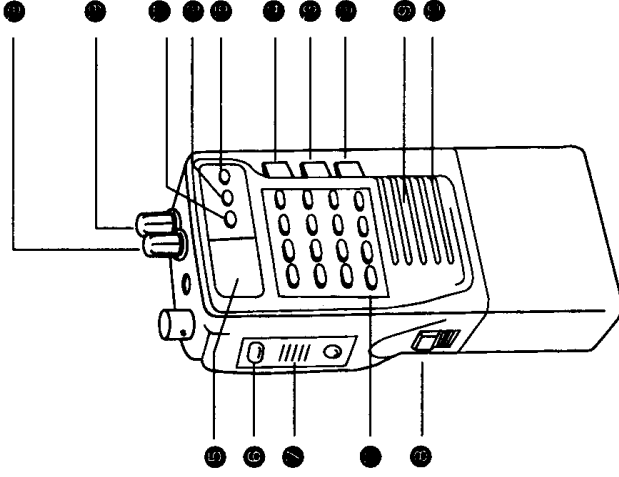

- ⑤ **LCD (liquid crystal display)** Displays all active functions.
- ⑥ **Function key**  
Push and hold this key to activate the secondary functions of other keys.
- ⑦ **PTT key**  
Push and hold to transmit; release to receive.
- ⑧ **Battery release**  
Used to change the battery case. Push and hold this knob upwards, then slide the battery case free of the transceiver.
- ⑨ **Speaker**  
Built-in speaker.
- ⑩ **Microphone**  
Built-in condenser-microphone.

● **Keyboard**

For transmitting DTMF signals, redialing, auto-dialing of memories, and other various settings/functions.

● **Tone key**

For setting the CTCSS tone function. (option)

● **MONI/H/L key**

Fully opens the squelch. Push the F key plus this key to select the output power (H: High/L: Low).

● **LAMP/KL key**

Push to light the lamp for approx. 5 secs. Push the F key plus this key to toggle the key lock function ON and OFF.

● **ANS/DIAL key**

Toggles the answer function ON and OFF. Push the F key and this key to enter the auto-dial input mode.

● **SCAN/CODE key**

Starts the scan. Push the F key and this key to enter the DTMF pager code input mode.

● **□□/C.ON key**

Toggles the squelch cancel function ON and OFF. While pushing the F key, this key toggles the simplex phonepatch function ON and OFF.

● **Power/volume control**

Turns the power ON and OFF and adjusts the audio output. Rotate clockwise to turn the power ON and to increase the volume.

● **Dial control**

Changes the memory channel number, tone frequency setting, etc.

3-2 LCD

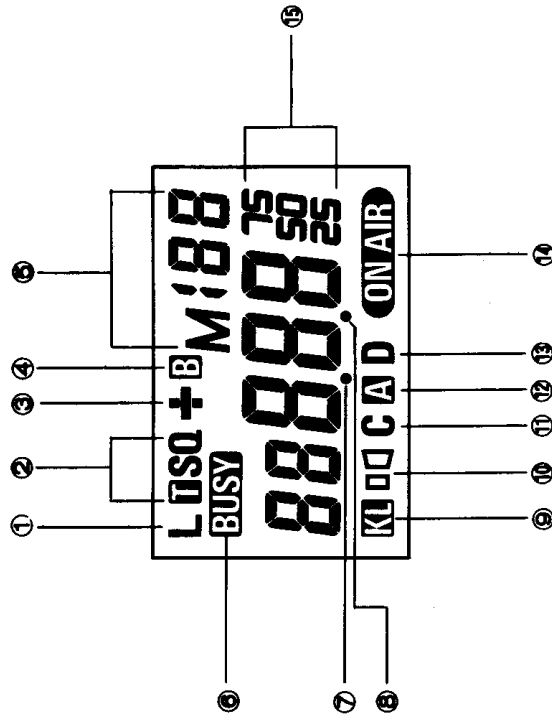

① **L**

Appears when transmit output power is set to low.

② **DSQ**

Appears while the tone encoder/tone squelch is set.

③ **+**

[+] or [-] appears when transmit frequency offsets are set. (Does not appear when a channel number is displayed).

④ **B**

Appears during low battery condition.

⑤ **M:88**

Indicates the memory channel number.

(Indicates the bank number when a channel number is displayed at ⑮).

⑥ **BUSY**

Appears when the squelch is open.

⑦ **.".**

Transmit/receive frequency decimal point (MHz). Flashes during scan.

# 4. BASIC OPERATION

## 4-1 RECEIVING

- Power ON and audio adjustment**  
Rotate the volume control clockwise to turn the power ON. Continue rotating clockwise to increase the audio output to a suitable level.
  - Setting the memory channel number**  
Rotate the dial control clockwise to increase the memory channel number and counterclockwise to decrease the memory channel number.
- Only memory channels with frequencies, etc. dealer-programmed will be indicated.

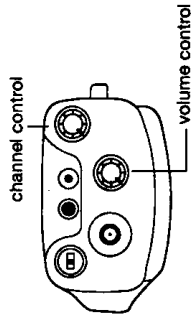

display type 1

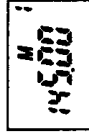

display type 2

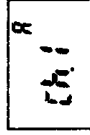

## 4-2 TRANSMITTING

- Setting a memory channel number**  
Set a memory channel number the same as for receiving.
- Push the PTT key to begin transmitting.**  
ON AIR appears in the LCD. Continue pushing the PTT key and speak normally into the microphone on the front panel to communicate.

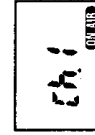
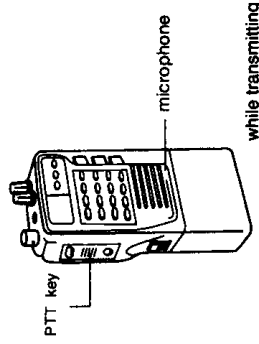

**Transmit time limits**  
(Time-out-timer)

After pushing the PTT for a specified time, the transceiver will automatically return to receive. (This time is set by your dealer in 30 secs. steps from 30 secs. to 450 secs.)

To continue transmitting after the transceiver returns to receive, release the PTT, then push and hold it to transmit again.

① " . "

Indicates the decimal point of a tone frequency (Hz). When in DTMF calling mode, flashes to indicate the DTMF squelch is open.

② **[KL]**  
Appears when the key lock function is activated.

③ **[DQ]**  
Flashes when the tone squelch or DTMF squelch is open.

④ **[C]**  
Appears when 3-digit codes are set in the DTMF pager mode (code squelch).

⑤ **[A]**  
Appears in the DTMF pager mode, when the 7-digit auto-answer function is ON.

⑥ **[D]**  
Appears when 7-digit codes are set in the DTMF pager mode.

⑦ **[ON AIR]**  
Appears during transmit.

⑧ Indicates the transmit/receive frequency or tone frequency.

**NOTE:** Display mode

This transceiver displays in one of the following modes set by your dealer.

1. Transmit/receive frequency mode



2. Memory channel number mode

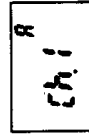

# 5. PRACTICAL OPERATION

## 5-1 SCANNING

### A) Frequency indication method

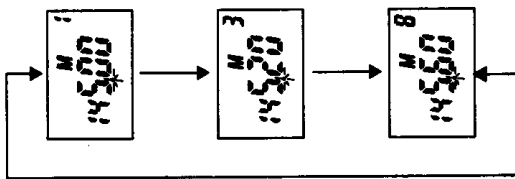

1. Push the scan key

The decimal point flashes and scanning begins.

2. During scanning, rotate the channel control clockwise to increase the displayed channel number and scanning proceeds in a positive direction; rotate the channel control counterclockwise to decrease the displayed channel number and scanning proceeds in a negative direction.

3. Push the SCAN during scanning to stop scanning.

(Scan operation)

When a signal is received, scan pauses for 5 secs. then resumes again. If the signal disappears before 5 secs. elapses, the scan resumes at that point.

Both the LAMP key and MONI key can be used during scanning.

**NOTE:** If scanning is not performed with the SCAN key while the radio is not key-locked (KL), the operation has been disallowed by your Dealer.

### B) Channel indication method

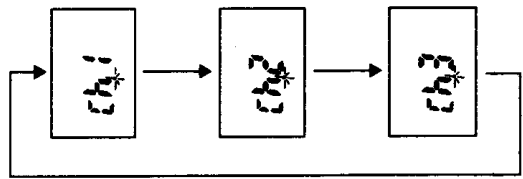

## 5-2 MONITOR FUNCTION

Pushing the MONI key is the same as squelch open. If nothing changes when pushing this key the operation has been disallowed by your Dealer.

## 5-3 LAMP FUNCTION

Push the LAMP key to activate the LCD backlighting. Pushing the key a second time or performing no operation for 5 secs. will turn the backlighting off. When the key lock function is activated, during scan or during any other operation, this function is still available. LAMP key remains active during the key lock (KL), scan, or any other operation.

## 5-4 LOW BATTERY INDICATION

B appears in the LCD when the battery is low.



## 5-5 KEY LOCK FUNCTION

Push the F key plus the LAMP/KL key to toggle between all keys locked and all keys unlocked.

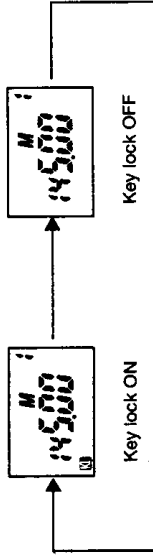

KL appears during key lock function ON and all keys except for LAMP, MONI, F, and PTT are locked.

## 5-6 SELECTING OUTPUT POWER

While pushing the F key, each push of the MONI/H/L key changes the transmit output power as illustrated below.

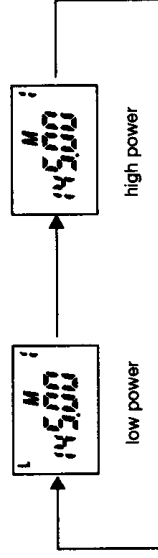

L appears when low output power is set.

**NOTE:** If KL does not appear or pushing the F key plus the H/L key does not change the output power, such operation has been disallowed by your dealer.

## 5-7 SIMPLEX PHONEPATCH

While pushing the F key, push the **ICON** key to toggle the simplex phone patch function ON and OFF.

This function emits a DTMF "C" code each time the PTT key is released.

## 5-8 BATTERY SAVE FUNCTION

This function can be set by your Dealer only. Battery saving is automatically carried out to increase the life of the batteries.

Even when this function is set by your Dealer, battery saving is not carried out during DTMF operation or scanning.

## 5-9 Bank Selection

A group of channels is referred as a Bank. There are four banks A to D, each containing 40 channels in the DJ-180B. The bank indication on LCD depends on how your dealer programs the radio to display channels:

- 1) if a channel number (without frequency) is displayed, the bank ("A", "b", "c", or "d") is displayed in the upper-right corner. Each bank has channels 0~39.
- 2) if a channel number and frequency are displayed, the bank is not displayed, but the channel number itself tells which bank you have selected:

Channels	
0~39	when in bank A
40~79	when in bank b
80~119	when in bank c
120~159	when in bank d

To select a bank, press and hold the Function key and press A~D on the keypad

## 5-10 APO (Auto-Power-Off) SETTING

### APO-On

Press and hold the Function key and press **6** to set APO. Leaving the radio for 30 minutes without operation or reception will turn the power off automatically. A warning beep is heard 30 seconds before the power off. To turn on the radio again, turn off and turn on with the power/volume control. Note: when turned off by APO, the radio is still dissipating small amount of power, and the radio should be turned off by the power/volume switch as soon as possible.

### SLEEP-On

Press and hold the Function key and press **5** to set SLEEP. Leaving the radio for 30 minutes without operation or reception will bring the radio into sleeping mode and will stay until a key (other than "keypad" keys) is pressed. A warning beep is heard 30 seconds before put to SLEEP. While in SLEEP the radio's receiver is not working, but is still dissipating small amount of power, and the radio should be turned off by the power/volume switch as soon as possible if not being used.

### APO-Off

Press and hold the Function key and press **4** to disable both the APO and SLEEP.

## 5-11 SQUELCH H/L

To set the squelch High (tight), press and hold the Function key and press **1**.

To set the squelch Low (loose), press and hold the Function key and press **2**.

## 5-12 CHANNEL SELECTION BY DIRECT KEY ENTRY

If your radio shows a channel-number only (without frequency), a channel can be selected by pressing the channel number after the #key. Example: To select channel 2, enter **#002**. Entry channel range is from **000** to **399**.

## 6. SELECTIVE CALLING

When contacting a specific station, a subaudible tone is superimposed over your voice for using tone squelch, or a DTMF code is transmitted prior to your voice transmission for using DTMF squelch. It is possible to use either method individually or in combination with each other.

### 6-1 TONE SQUELCH

For the purpose of transmitting to a specific station, a subaudible tone is superimposed over your voice signal. This function may be preset by your Dealer beforehand, or can be temporarily changed by the user if so permitted and programmed by your Dealer.

#### (1) Setting the tone frequency

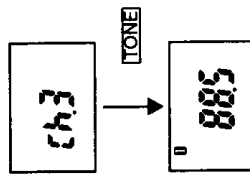

1. Push the **TONE** key; the tone frequency is displayed.

2. Rotate the dial control clockwise to move up and counter-clockwise to move down. Choose from 1 of 38 different tone frequencies as listed below.

67.0	71.9	74.4	77.0	79.7	82.5
85.4	88.5	91.5	94.8	97.4	100.0
103.5	107.2	110.9	114.8	118.8	123.0
127.3	131.8	136.5	141.3	146.2	151.4
156.7	162.2	167.9	173.8	179.9	186.2
192.8	203.5	210.7	218.1	225.7	233.6
241.8	250.3				

#### (2) Tone encoder/tone squelch function setting

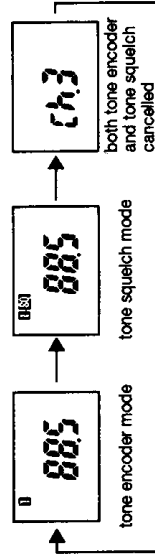

3. After the tone frequency appears, push the **TONE** key to step through the function settings as indicated below.

4. Push the **ANS** key to return the beginning display.

**NOTE:** If you push the **TONE** key and tone setting is not performed (even though KL is not displayed) operation has been disallowed by your Dealer.

### 6-2 DTMF SQUELCH

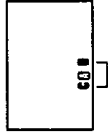

In order to contact a specific station, a DTMF code is transmitted prior to your voice signal. The DTMF code can be heard from the speaker while the DTMF signals are being emitted. Beforehand, one of the four DTMF pager modes must be set in the transceiver. Check to make sure the mode you want to select is indicated in the display.

C appears: 3-digit pager mode (pages 13-14)

D appears: 7-digit pager mode (pages 15-18)

AD appears: 7-digit pager/auto answerback mode (pages 15-19)

None of the above appear: DTMF squelch is cancelled

#### 6-2-1 3-digit pager mode

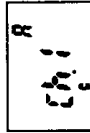

C appears to indicate the transceiver is in 3-digit DTMF pager mode (code squelch). When you receive a DTMF code that agrees with your own DTMF code, the squelch opens.

#### Transmitting

While pushing the **PTT**, enter the receiving station's code. (Time between pushing keys must be within 2 secs.)

#### Receiving

When the transceiver receives an appropriate 3-digit DTMF code the squelch opens. At the same time a calling signal is emitted for 10 secs. Perform any other operation to stop this signal.

If no operation or action is performed within an additional 10 secs., the transceiver's squelch closes again.

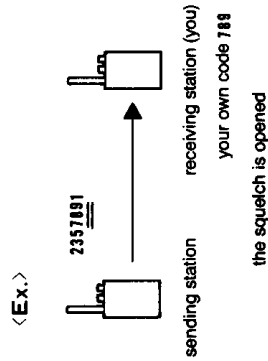

### Confirmation and setting your own station code

Your own code is made up of a 3-digit number. Follow the procedure below to set a desired code.

1. When C is displayed: while pushing F, push the code key. The current code is displayed.

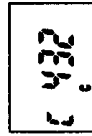
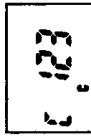
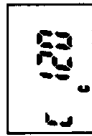
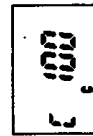
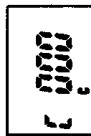

...

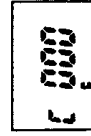
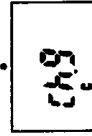

2. Use the keyboard to enter the desired code (starting from the 1st digit). Entering more than 3 digits will overwrite previously entered digits.

**NOTE:** Only numeral keys may be entered.

### 6-2-2 7-digit pager mode

D appears to indicate the 7-digit pager mode. The 7-digit mode is used to call specific stations on an individual basis. In particular, where permissible the Dealer can set group calls.

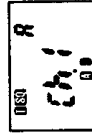

#### (1) Transmit

#### Transmit code configuration

The 7-digit code to call a station consists of the following.

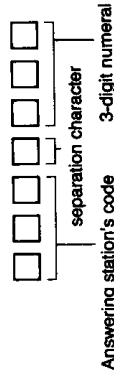

#### Transmit method

- A. Enter keys according to table 1 "key input code." Pushing the  $\rightarrow$  key transmits the entered code.
- B. While pushing the PTT, push keys to transmit codes on a real-time basis. Refer to table 1 "transmit codes" for details.

#### Calling a group

Where permissible by the dealer, "A" can be used to substitute other numbers (0 to 9) of a specific station's code. For example, entering "12A" will call all stations with codes "120" to "129." The "A" may be used for more than one digit.

Push the ANS key or PTT to return to the initial display.

To clear a code during input or for the exiting code: while pushing F, push C.

**Table 1 7-digit pager format**

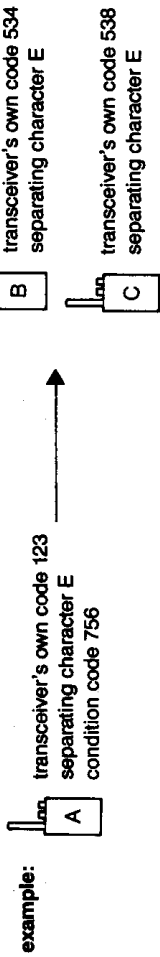

example:

< Individual call > To transceiver B only

	Key entry	Transmitted code
Transmitting without self identification/own code	5 3 4 # * Note 1	5 3 4 E B B B Note 3
Transmitting a key input code (arbitrary)	5 3 4 # 9 9 9 * Note 2	5 3 4 E 9 9 9
Transmitting the transceiver's own code	5 3 4 # # 1 *	5 3 4 E 1 2 3
Transmitting the condition code	5 3 4 # # 2 *	5 3 4 E 7 5 6

**NOTE 1:** The 4th digit is dealer pre-programmed separation character.

**NOTE 2:** Arbitrary 3-digit numeral code, for example 999.

**NOTE 3:** "BBB" is used as transceiver A's own dummy code: This paging allows the simplest key entries to page the other party.

< group call > To call transceivers B and C but no others.

	Key entry	Transmitted code
Transmitting without self identification/own code	5 3 A # *	5 3 A E B B B
Transmitting a key input code (arbitrary)	5 3 A # 7 5 1 *	5 3 A E 7 5 1
Transmitting the transceiver's own code	5 3 A # # 1 *	5 3 A E 1 2 3
Transmitting the condition code	5 3 A # # 2 *	5 3 A E 7 5 6

**(2) Condition code setting and confirmation**

Condition codes are made up of 3-digit numerals. Follow the procedure below to set a code.

1. While D appears: while pushing the Function key, push the CODE key.  
The current condition code is displayed.

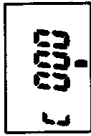

2. Enter numeral keys using the keyboard. Enter in order from the first to last digit. Entering more than 3 digits will overwrite previously entered digits.

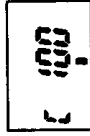

**NOTE:** Only numeral digits may be entered.

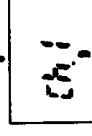
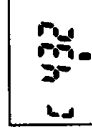
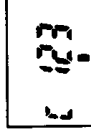
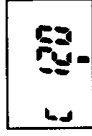

3. Push the ANS key or PTT to return to the beginning display.

4. To clear a condition code while entering or to clear the existing code, while pushing the F key, push the C key.

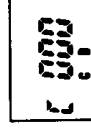

### (3) Receiving

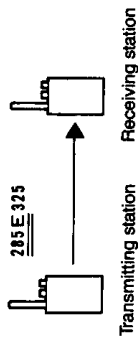

Receiving station  
Transceiver code (285) +  
intermediate code (E) opens  
the squelch.

When the transceiver receives the four matching digits that you pre-programmed (your own 3-digit transceiver code + 1-digit separating character), the squelch opens and you can hear the transmission.

Your transceiver's own code and separating character are dealer programmable in the 7-digit pager mode

After the squelch opens, the LCD continues to display the 3 digits received. Upon subsequent key operation, the LCD returns to the previous display.

Receiving dummy code (BBB) display

- Ⓛ : Personal call
- Ⓛ : Group call

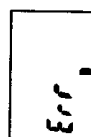
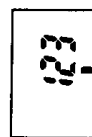
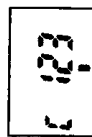
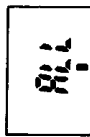
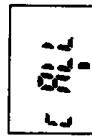

The displayed 3-digit number indicates reception of one of the codes below.

- Transmitting station's own code
- Transmitting station's condition code
- Transmitting station has arbitrarily selected a code

- Ⓛ : Personal call
- Ⓛ : Group call

If the 3-digit transmitted code was not received properly, this display appears.

### (4) Answerback

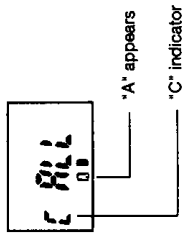

When a personal call has been received while "A" is indicated in the LCD, and answer will be automatically sent back. The method of answering back is set by your Dealer.

1. The transceiver's own code is sent as an answer back
2. The condition code is sent as an answer back
3. A single tone is sent as an answer back

When "A" is not indicated, or when receiving a group call, an answer back will not be sent, and the radio will beep for 10 secs. Beeping stops upon subsequent operation.

When no operation is carried out, or no signal is received for 10 secs., the squelch returns to its previous condition.

When permitted by the dealer, answerback can be turned ON and OFF.

If after turning the power ON, "A" and "D" appear, push the ANS key. "A" disappears, and the answer back function is turned OFF. Push the ANS key again and "A" appears once more.

**NOTE:** If, after turning the power ON, "A" and "D" do not appear, your Dealer has disabled turning answerback ON and OFF. In this case, pushing the ANS key will have no effect.

### 6-2-3 DTMF cancel mode

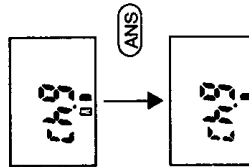

Turning answerback ON/OFF

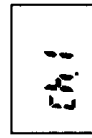

Auto-dialling and redialling are also possible.

When neither "C", "A", or "D" is displayed, the transceiver is in DTMF squelch cancel mode. Although received codes cannot be checked for agreement, transmit is possible.

#### Transmit method

While pushing the PTT, numeral codes are transmitted as pushed in real time.

### 6-2-4 Autodial

This function sends a DTMF code in memory automatically. 7 code memories can each hold one DTMF code of up to 24 digits.

#### Setting an auto-dial code

1. Set mode  
While pushing the Function key, push the DIAL key. The last 3 digits of the presently set DTMF code appears.  
**NOTE:** If no data has yet been entered " . . . " appears.

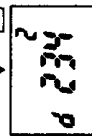
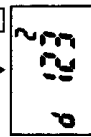
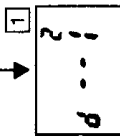
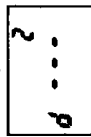
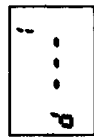

2. Select a code memory No.  
Rotate the dial control to select one of memories 1 to 7.

3. Enter a code  
Use the keyboard to enter the desired code. (All 16 keys can be used.) When pushing a key, the entering digit appears to the right and the previously entered digit appears to the left. Up to 24 digits can be entered per code.

If you make a mistake while entering, while pushing the F key, rotate the dial control clockwise. The most recently input digit disappears. Enter the desired digit. To advance the display, while pushing the F key, rotate the dial control counterclockwise.

4. Clearing a code  
To clear a code you are entering, or to clear a code that has already been entered: while pushing F, push C.

#### Autodial

While either the frequency or a channel is displayed, push the \* key; then, within 4 secs. enter an autodial No. (1 to 7). The corresponding code is then sent. The code being sent can be heard from the speaker.

**NOTE:** If an autodial No. is pushed over 4 secs. after the \* key, or if an autodial No. is not in memory, no transmission will take place.

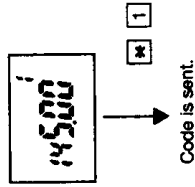

**Keyboard Indication**  
There are 16 different autodial codes that can be entered. Use the table below to choose valid inputs.

key	0	1	2	3	4	5	6	7	8	9	A	B	C	D	X	#
display	0	1	2	3	4	5	6	7	8	9	A	b	c	d	E	F

### 6-2-5 Auto-redial

You can automatically redial the last DTMF code transmitted.

1. While the display indicates a frequency or channel No., push the \* key.
2. Within 4 secs. push the \* key again. The transceiver then automatically redials the previously transmitted DTMF code. The transmitted DTMF codes can be heard through the speaker as they are sent.

**NOTE:** The second push of the \* key must be within 4 secs. of the first push or redialing will not take place.

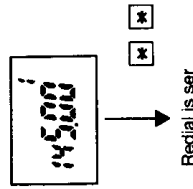

### 6-3 DTMF SQUELCH AND CTCSS TONE SQUELCH (SQUELCH SYSTEM)

To communicate with a specific station using DTMF squelch see p. 13 and using CTCSS tone squelch see p. 12. The following explanation deals with combining these two methods into a squelch system.

**(1) DTMF/CTCSS both off**

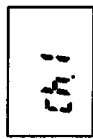

Received signals can be heard. Push the PTT to transmit normally.

**(2) CTCSS Tone squelch only**

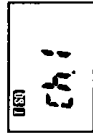

When a tone signal matching your set tone is received the squelch opens. Push the PTT to transmit. When a tone signal that doesn't match is received, the squelch does not open. Trying to transmit in such a case will only cause BUSY to flash once.

**(3) DTMF squelch only**



<no signal>

Push the PTT, the decimal point appears and transmission begins. 10 secs. after the end of the transmission the DTMF squelch remains open and transmitted signals can be received. If no operation is performed and no signal is received for 10 secs., the transceiver returns to the DTMF squelch condition.

**NOTE:** The decimal point appears to indicate the DTMF squelch is opened.



appears

appears for 10 secs. after transmission ends

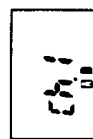

Disappears 10 secs. after a signal disappears or no operation is performed.

**(4) Both DTMF and tone set**



<no signal>

Push the PTT, the decimal point appears and transmission begins. 10 secs. after the transmission ends, the DTMF squelch closes. During this time, if a matching CTCSS signal is received, the received audio can be heard. When no operation is performed or no carrier is received for 10 secs., the DTMF squelch returns to its closed condition.



appears

appears for 10 secs. after signal disappears or when no operation is performed.

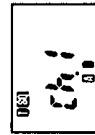

<Signal present>

The squelch opens and a signal can be heard only when both a matching DTMF signal and matching tone signal is received. When no operation is performed and no carrier appears for 10 secs., the DTMF squelch returns to its closed condition. If either an unmatched tone or DTMF signal is received, the signal cannot be heard. Pushing the PTT will cause BUSY to flash once.

**(5) Cancelling DTMF/CTCSS tone squelch temporarily**

While DTMF/CTCSS tone squelches are set, push **[ ]** to cancel them.

**(6) Busy Channel Lock Out**

During DTMF/CTCSS tone squelch setting, if a carrier with an unmatched tone or code is received or if the PTT is pushed, and an invalid operation beep sounds where transmission cannot take place, Busy Channel Lock Out has been set by your Dealer. Transmit can take place when the carrier disappears or when **[ ]** appears in the LCD.

**6-4 TIME-OUT TIMER/PENALTY**

- If your radio stops transmitting automatically after a certain length of continuous transmission, your radio may have been dealer-programmed with the Time-out Timer (TOT). The purpose of TOT is for letting other radios share the channel. There is a warning beep 10 seconds before time-out-limit. After timing out, release and re-press the PTT to transmit again.
- If your radio cannot re-transmit for a few seconds after timing-out by TOT, a penalty time may have been dealer-programmed; you can re-transmit after the set penalty time lapses (usually a few seconds). The Penalty allows a "window" for other radios to access the channel after you time out. A low-tone error beep sounds in an attempt to transmit during penalty.